



American Welding Society

***RECOMMENDED
PROJECTS & SCORING CRITERIA***

For State



SkillsUSA®

***WELDING
Championships***

Forward

The National SkillsUSA welding competition has a long history. The National championships started in 1964 with Mr. Andy Godley from Alabama Power and Mr. Gene Hornberger from Newport News Shipbuilding at the time. Along with a number of other supporters, they scraped together the National welding competition by having the competition at a local school and borrowing any and all equipment they could just to hold a competition. They continued to do this until around 1978 when help to support the National competition with equipment became more available and the indoor convention center welding competition began for the National championships. Today, As the competition need for equipment grew, both Miller Electric Mfg. and The Lincoln Electric Co. spends 1 one week a year with their gloves off to come together and support the future of the welding profession. Only SkillsUSA offers the spirit, dedication, and sacrifice that is worthy of two fierce competitors coming together to support educators and students as they pursue excellence in their profession through competition.

SkillsUSA embodies the very need for our industry to recruit, reward, and recognize excellence in their craft. The many students that compete and earn medals in SkillsUSA competitions at every level quickly become role models in their welding class. Students entering their local welding program see other students before them that are successful medalists with SkillsUSA and that becomes motivation for a new student to try that much harder to be excellent at their profession.

Healthy competition is what makes us better at what we do. Just look at the first two Official Sponsors for SkillsUSA, Lincoln and Miller. Two highly competitive welding equipment manufacturers. Without the other, there would be no one pushing the other to be innovative or to continuously improve their products benefiting the consumer. Competition is healthy to help you improve and benchmark your skills against someone doing the same profession as you to make you better.

This is not new that SkillsUSA is an outstanding tool to elevate the welding profession in all levels. Repeating Mr. Gene Hornberger's words from the fourth edition of this document is still appropriate and true although today, 'vocational education' is more appropriately referred to as CTE (Career and Technical Education):



Vocational Education is a vital portion of the educational system in the United States. American Industry continues to need a steady supply of skilled craftsman and in particular, Welders. In spite of the need for skilled craftsman vocational technical education carries with it a stigma that those who are vocational students are simply there because they are not capable of higher academic education. The Vocational Industrial Clubs of America (now SkillsUSA)

was formed to reverse that image. SkillsUSA recognizes that most vocational students have made a conscious decision to enter the trades to pursue a rewarding and satisfying career.

SkillsUSA established the United States Skills Olympics (now called SkillsUSA Championships) as a method of recognizing and rewarding vocational students for demonstrating trade skills. It serves as a challenge to vocational students to do their best. There are a great many in-

dividuals and organizations who believe in the SkillsUSA objectives and the impact of these objectives on the lives of the thousands of students SkillsUSA serves. They have done so because they want to improve the quality of the vocational programs and better prepare the students for gainful employment. The American Welding Society is among the largest supporters of SkillsUSA. SkillsUSA contests begin at local vocational schools where contests are held to determine those who will advance to the regional level. The regional winners compete in state contests to determine those who will represent their states in National competition. There are two levels of competition, Secondary and Post Secondary. Not all states have Post Secondary SkillsUSA programs, but most do have secondary programs.

The Education Committee strongly recommends AMERICAN WELDING SOCIETY Section involvement at every level of competition to provide quality contests. This publication has been prepared using the experience gained in local, national and international SkillsUSA contests to provide a guide for those wishing to run a SkillsUSA welding skills contest at any level. To get involved in the SkillsUSA welding contests you need to know who is in charge of the SkillsUSA program in your area. National SkillsUSA will provide you with the name address, and telephone number of your State SkillsUSA Director, so you can determine when the Welding skills contest will be held, and to volunteer your Section's services. You can contact National SkillsUSA at:

*National SkillsUSA
P.O. Box 3000
Leesburg, Virginia, 20177
Tel: (703) 777-8810
Fax: (703) 777-8999
Web: www.skillsusa.org*

*Eugene G. Hornberger
(Sep 29, 1938 - May 22, 2017)
Author of the First to Fourth editions of this document.
SkillsUSA Welding Committee 1965-2015*

To reiterate Mr. Hornberger, The American Welding Society is the perfect authority figure to be engaged with SkillsUSA Welding programs at all levels. From local regional competitions to the State Competitions and on to the SkillsUSA National Championships. AWS can provide a number of resources to conduct a fair and transparent SkillsUSA Welding competition.

As we always learn from those before us, having been privileged to work with Mr. Hornberger for a number of years supporting the National welding competition, the National SkillsUSA Welding Technical Committee has redeveloped the score system to an objective system based on AWS Visual Inspection Criteria, and making it a little more strict, so that good welders can be separated by their ability to produce sound consistent welds that meet the competition criteria.

The team listed in this document has significant experience gained by managing welding competitions on all levels from local regional, State and National SkillsUSA Welding Competitions that combined exceeds well over 100 years of experience. This is a refined a system that has been continuously improving and will continue to improve to eliminate any perception of an unfair welding competition. Like golf, everyone will know the rules, it's how you execute to those rules that day that separates you.

Good Luck!
-The National Welding Technical Committee

SkillsUSA National Welding Technical Committee

Ed Norman – Co-Chair	<i>EDCO Industries, LLC</i>
Ashley Applegate – Co-Chair	<i>Kentucky Welding Institute</i>
Martica Ventura – Secretary	<i>American Welding Society</i>
Nick Peterson – Scoring	<i>Miller Electric Mfg. LLC</i>
Lawrence Adam	<i>Matheson Tri-Gas, Inc.</i>
Jim Bridwell	<i>Ozarks Technical Community College</i>
Lee Caughron	<i>Grand River Technical School</i>
Shirley Day	<i>Hillyard Technical Center</i>
Daniel Dye	<i>South Central Career Center</i>
Justin Fort	<i>Hypertherm</i>
Andy Godley	<i>Alabama Power Company</i>
Blaine Guy	<i>Hobart Brothers, LLC</i>
Darren Haas	<i>Ingalls Shipyard</i>
Steve Houston	<i>ATP Inc.</i>
Dan Klingman	<i>The Lincoln Electric Co.</i>
Adam Melton	<i>Grand River Technical School</i>
Branden Muehlbrandt	<i>The Lincoln Electric Co.</i>
Chandler Vincent	<i>WelderMade</i>

American Welding Society, 8669 NW 36 Street, # 130 Miami, Florida 33166-6672

© 2020-2023 by American Welding Society. All rights reserved

Printed in the United States of America

Photocopy Rights

Authorization is granted to photocopy items for educational classroom and welding competition use only.

Important Scoring Notes:

This document is written to support an initiative by SkillsUSA in an effort to bring all SkillsUSA Welding competitions to a level playing field. This document provides project samples and scoring tools to help execute a SkillsUSA Welding Competition. **Ultimately every situation is different and the idea is to share best practices that align with each other and most importantly, they share scoring criteria.**

Every State competition has its own unique circumstances and not everything in this document will work for every state. This is intended to be a guide and offer a set of tools and a culmination of many years of experience in managing SkillsUSA Welding Competitions on all levels.

The intent of this document is to help execute a fair contest that aligns with the National Championships. Using these projects will help the Gold Medalists from your state compete at the National Championships, effectively making the National competition more difficult to judge and prepares your state competitor with the best opportunity to excel in National competition.



Figure 1 – Allowable discontinuities by evaluation type.

All of the scoring questions are designed to be generic in nature to be adaptable to any project you choose to apply the questions to. The Weld Number is blank because applying all questions to all welds is very time consuming. The idea is to choose which welds to apply the questions to. In some cases the question just may not apply. You can choose to give the point or design a new question. Questions get their roots from AWS D1.1 Visual Inspection Criteria but become more stringent than Code to quickly, fairly, and accurately separate the highest performers to make a top 3 rank.

This is intended to be a guide to learn from, to help execute and manage a fair and transparent SkillsUSA welding competition. It is intended for all states to use so that everyone is at least scoring to the same criteria to level all SkillsUSA welding competitions. Golf is not played different anywhere else because it does not make sense to use different rules for golf in different areas to determine the winners. We can hope that we can do the same for SkillsUSA welding competitions where the national contest becomes so close to judge, that some of the extreme scoring used for the WorldSkills competitions will be needed. If all states are working to the same set of scoring criteria for their projects, the National competition will be quite a spectacle for the hope for of our industry's future. Additionally once all states are on the same page for scoring, the project will not matter, and we can continue to improve how we score. Now is the time however that we must all at least begin to evaluate welds the same way. 0-10 is not defensible and has no criteria to defend your position.

Judges And Judging

Judges are important to a successful contest. It is essential to have fair and impartial judging. Judges that are selected should be familiar with the processes and materials they are judging. Sources of judges are engineers, foremen, inspectors, project superintendents, Certified Welding Inspectors, welders, technicians, and salespersons.

Using the contest drawing, the judges can select what welds the score criteria will be applied to. A sufficient number of examination points provide a good evaluation of the project and these are based on AWS D1.1 Structural welding Code for Steel Table 6.1 Visual Inspection Criteria, as a baseline and WorldSkills .

These points are applied to the welds in a statistical way. A question can be applied to a single weld, or to all welds, or to just fillet welds, or however the judge team determines they have time to make sure they evaluate the exact same way for all competitors. This is a part of the competition that the incoming competitors do not know so the competitor needs to prepare that all welds are evaluated with all questions. The reality is that the competition time frame does not allow the time to evaluate all welds to this detail so a snapshot is determined and all competitor projects become evaluated in the exact same way that is clearly defined.

Not all welds need to be evaluated with all questions, this is a statistical analysis that is fairly applied to everyone. In other words on contest day the judges choose which golf holes will be scored because we do not have time to score the entire course.

Before the first project is evaluated the judge team for that process will mark their master drawing and their score booklet to identify the welds that each question is evaluating so that the team maintains consistency. Additionally this team must be the same people for ALL competitors. Judges should not change from the beginning to the end. The only time judges could or should change throughout a day may be College Post Secondary vs. High School Secondary as those are essentially separate contests. The same judges should evaluate the entire group to ensure consistent scoring for that portion for all competitors.

Each contestant should be judged by a minimum of three different judges, all of whom shall not know the contestant. SkillsUSA rules require each contestant be assigned a number, their name and school are known only to the contest chair. The identity of contestants is revealed only after the contest is concluded, and the winners selected.

Judging of the welded projects should be in compliance with the criteria outlined in this document to maintain consistency among all welding competitions for SkillsUSA to ensure consistency in evaluating the weldments. Welding code criteria is tough but not as tough as the criteria needs to be for a welding contest. When you have a number of welds that all may pass welding code criteria, how do you separate the best of the best when their welds are all good? The score questions in this document have been used for many years and they clearly separate the better welders from the not as good.

In the event of a tie, the first area that identifies a score separation will separate places. Those areas will be looked at in this order until the first separation occurs and that will determine place:

1. Safety Violations
2. Clothing Penalty
3. Resume Penalty
4. Knowledge Test
5. Visual Test
6. Interview
7. GMAW
8. GTAW
9. FCAW
10. SMAW
11. PAC
12. OFC
13. GMAW/FCAW IPJ
14. GTAW/SMAW IPJ

The last resort will be to line up the tied projects, and at the discretion of the Contest Chairman, 5 individual experts will be selected to vote the ranking based on their professional opinion. It is only at this point that subjectivity will select a winner.

The Results are broken down by contest area and you can see on the table and pie charts above how those results fit with the areas evaluated.

Good Luck!

The goals of the SkillsUSA Welding Technical Committee are to operate an honest, fair, and rewarding contest. Everyone involved in managing this contest truly strives to make that happen in an effort to reward excellence among America's future welding workforce.

We all wish you the best in the competition and in your welding careers!

Respectfully,

The National Welding SkillsUSA Technical Committee

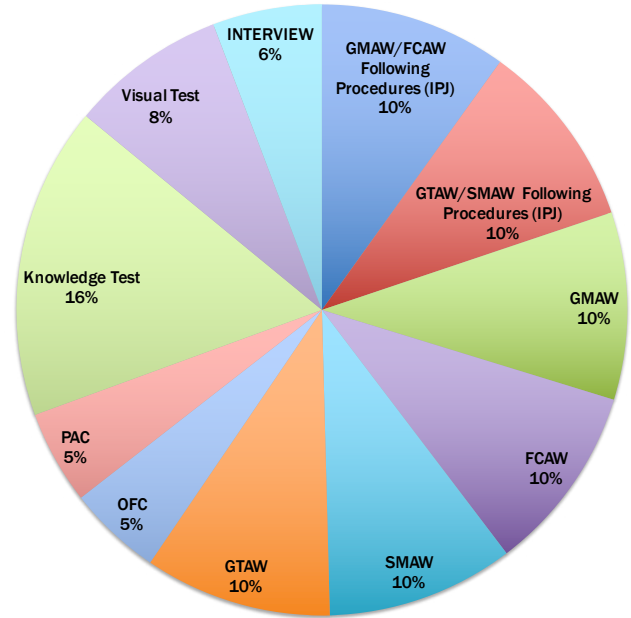

Figure 2 – Breakdown of Contest Areas (These are the points that you will see from SkillsUSA)

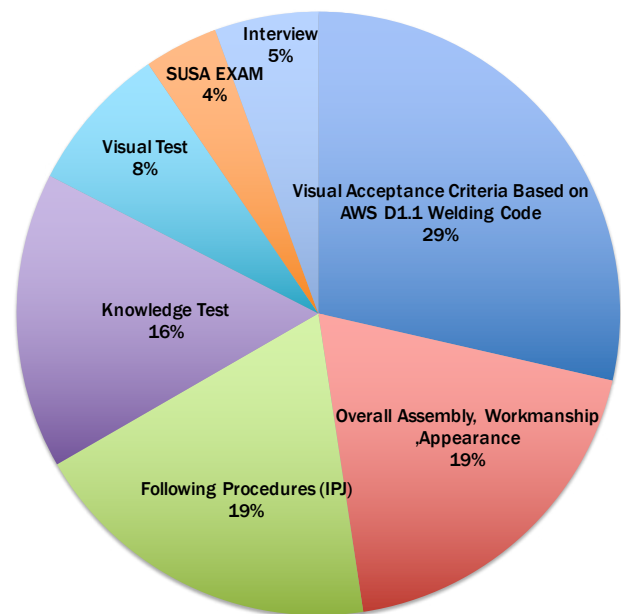

Figure 3 – Areas that the Scoring System Evaluates

NEW Projects for 2022 and Beyond

When this committee was challenged with a virtual welding competition it was imperative we had a fair competition in potentially 100 locations. The American Welding Society stepped in right away to find impartial Certified Welding Inspectors to conduct the scoring across the nation. AWS hosted webinars to coach the CWI's to use our scoring system and the results were far better than we expected. With as fair as possible Judging figured out, next was how do we get projects to competitors.

Getting parts for a contest is difficult and expensive. As many of us know to ask for favors from our advisory committees can be uncomfortable and many times you are last on the list because of production schedules. Metal is expensive unless you are buying in bulk. We had to find a way we could affordably ship projects across the nation that were all identical.

Mentioning specific companies to purchase items through is difficult for this committee. We appreciate and support all of our sponsors in many ways. Our project kit supplier is an exception. Weldermade.com was able to quickly deliver laser precision projects to all competitors across the nation for the 2021 at home competition. Without this effort, a fair virtual national contest would not have been possible.

Weldermade.com is owned and operated by a former SkillsUSA World-Skills Welder who is positioned to elevate our project quality and offer it at cost. The creativity and passion as well as past competition experience leave the future wide open to raise the bar for both quality and equality for all competitors to have the same fair and consistently executed and evaluated experience nationwide.

The first two drawings represent typical expectations for the National projects except smaller for shorter times (30 minute vs 1 hour per process). For those that participated in the Virtual National Championships in 2021, the project parts are all laser cut to a high degree of precision. Weldermade.com supplies our parts and donates much of his time to prepare them. Weldermade.com is not profiting from the SkillsUSA Competition or Practice Kits.

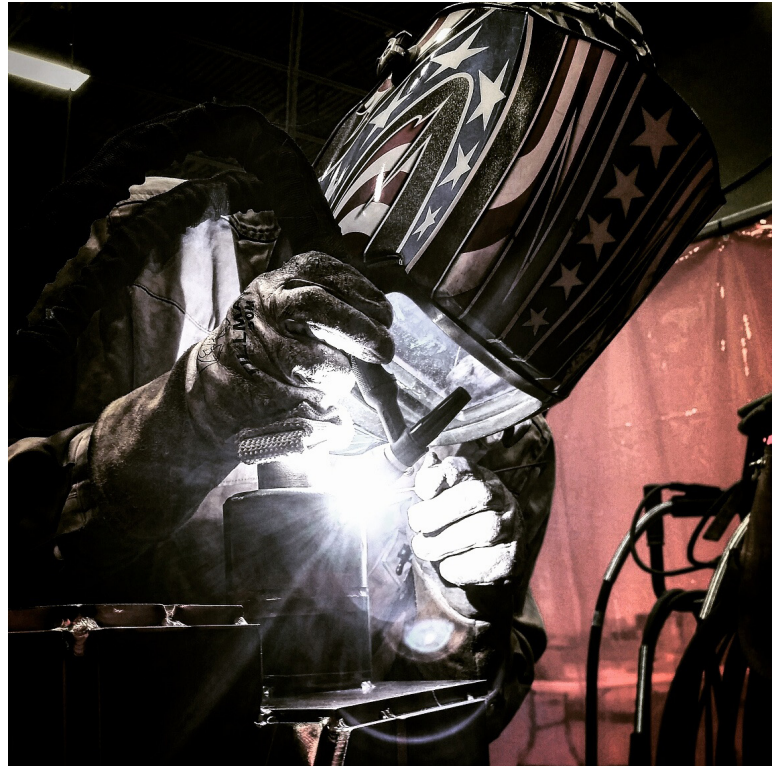

Are you managing a SkillsUSA
welding contest and need
multiple kits?

Contact:
Chandler Vincent ASAP!
chandler@weldermade.com

(435) 232-6426
weldermade.com

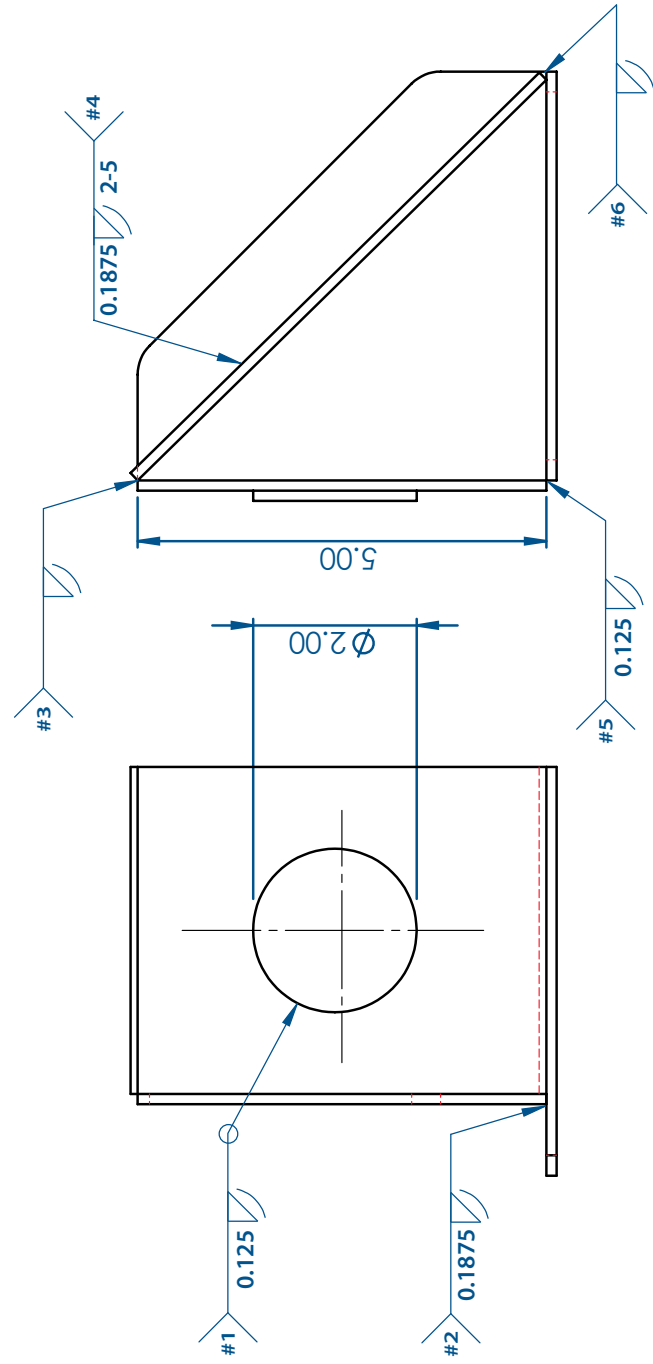
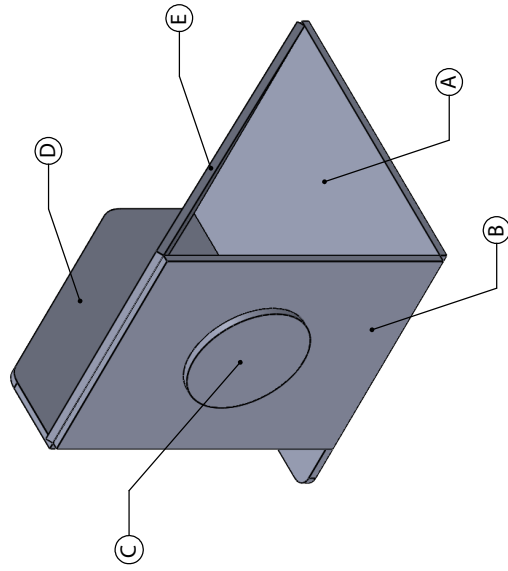
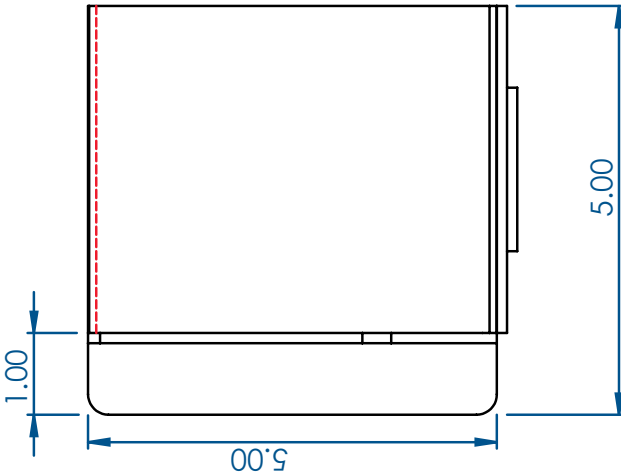

ID	QTY.	DESC.
A	1	0.125 x 5 x 5
B	1	0.125 x 4 x 5
C	1	0.125 x 2 Dia.
D	1	0.125 x 5 x 5 Gusset
E	1	0.125 x 4 x 7

ALL PROCESSES TO BE COMPLETED WITH THE MATERIALS PROVIDED

1. TACK COMPLETE ASSEMBLY IN ANY POSITION.
2. WELDING TO BE COMPLETED WITH PLATE A FLAT TO THE TABLE
3. ALL VERTICAL WELDS TO BE WELDED IN THE UPHILL PROGRESSION.
4. NO POST WELD CLEANING ALLOWED

TITLE: STATE



Welding Contest

DWG. NO.

GTAW - Aluminum

THE INFORMATION CONTAINED IN THIS DRAWING IS THE SOLE PROPERTY OF WELDERMADE.COM. ANY REPRODUCTION IN PART OR AS A WHOLE WITHOUT THE WRITTEN PERMISSION OF WELDERMADE.COM IS PROHIBITED.

STATE SUSAT

SHEET 1 OF 1

PART	DESCRIPTION	QTY.
A	7" x 6" x .25	1
B	6" x 6" x .25	1
C	5" x 4" x .25	1
D	7" x 5.75" x .25	1
E	2.5" circle .25	1
F	3.75" x 5.75" x .25	1

ALL PROCESSES TO BE COMPLETED WITH THE MATERIALS PROVIDED ALL WELD PROCESSES/PROCEDURES ASSIGNED BY TECHNICAL COMMITTEE

1. TACK AND COMPLETE ASSEMBLY IN ANY POSITION.
2. WELDING TO BE COMPLETED WITH PLATE A FLAT TO THE TABLE
3. ALL VERTICAL WELDS TO BE WELDED IN THE UPHILL PROGRESSION.
4. Weld #7 WELD COMPLETE ASSEMBLY B&C

TITLE: STATE



WELDING CONTEST

DWG. NO. SMAW,GMAW,FCAW-G

welder-made.com SHEET 1 OF 1

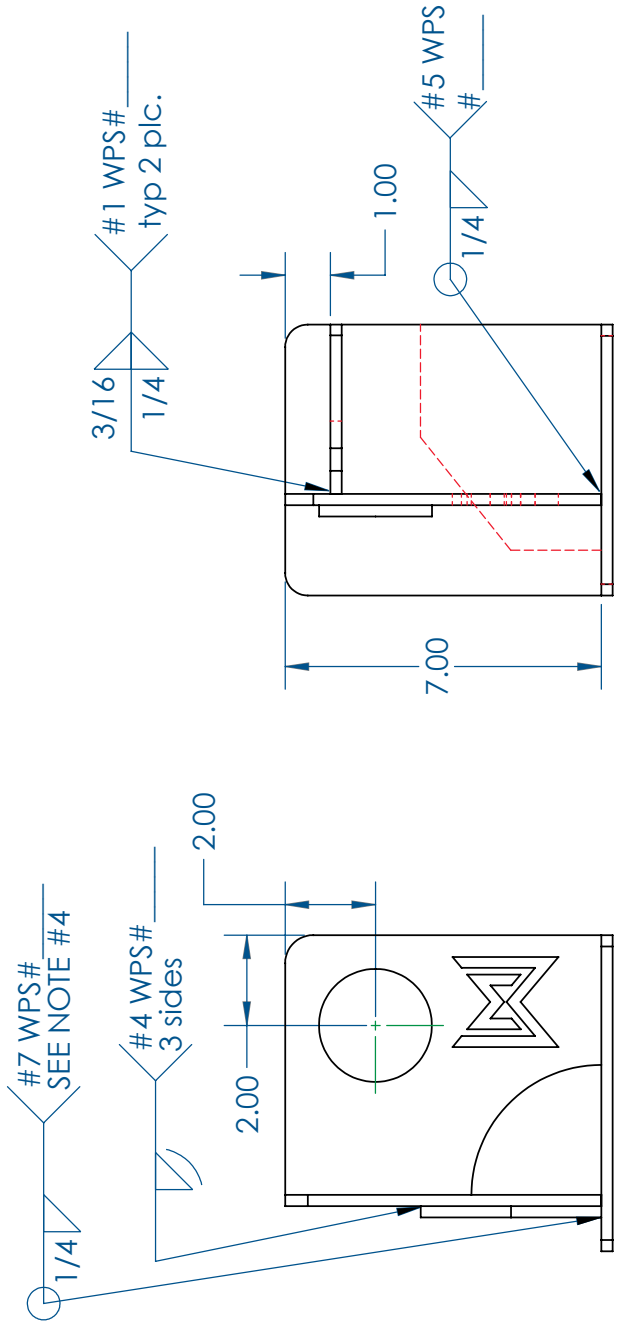
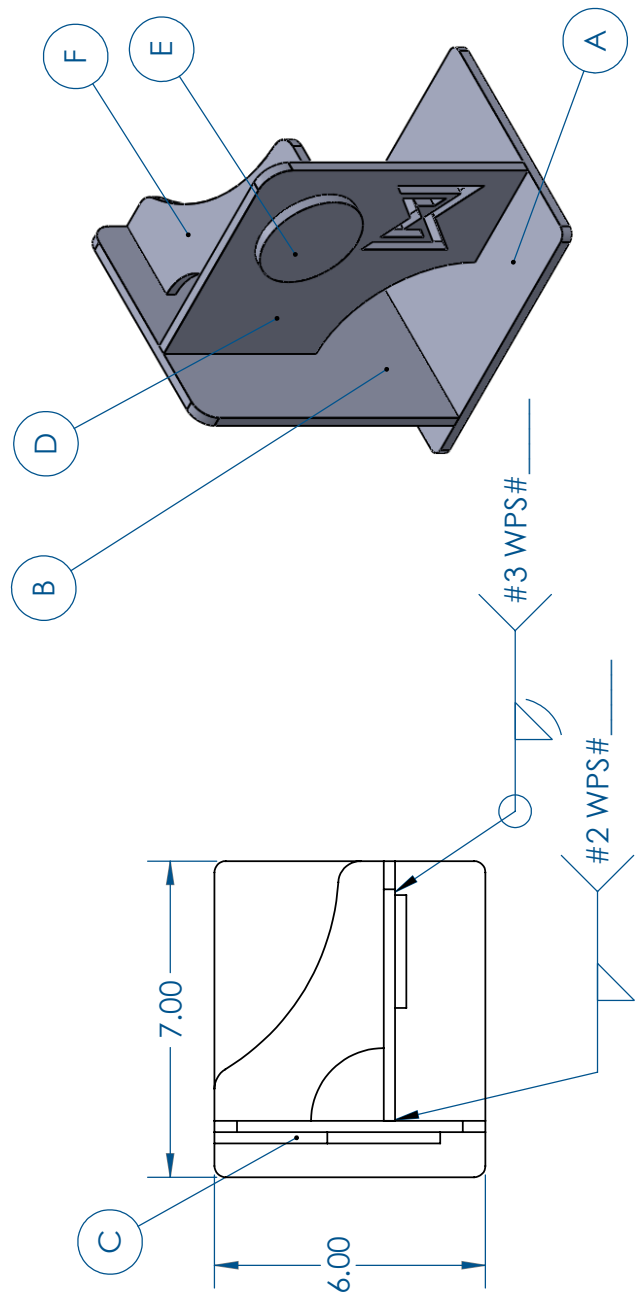

THE INFORMATION CONTAINED IN THIS DRAWING IS THE SOLE PROPERTY OF WELDERMADE.COM. ANY REPRODUCTION IN PART OR AS A WHOLE WITHOUT THE WRITTEN PERMISSION OF WELDERMADE.COM IS PROHIBITED.



WELDERMADE



Looking for State-Level SkillsUSA Welding Practice Kits?

Find those **HERE** @

WelderMade.com

Are you managing a SkillsUSA welding contest and need multiple kits?

Contact:

Chandler Vincent ASAP!

Chandler@WelderMade.com

(435) 232-6426

OR

Order Your State Competition Kits **HERE**

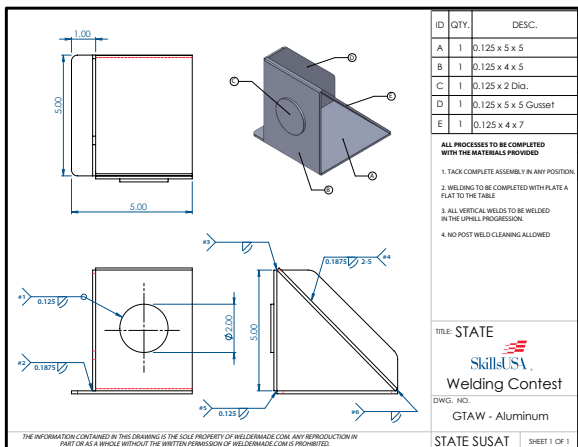

Aluminum Project

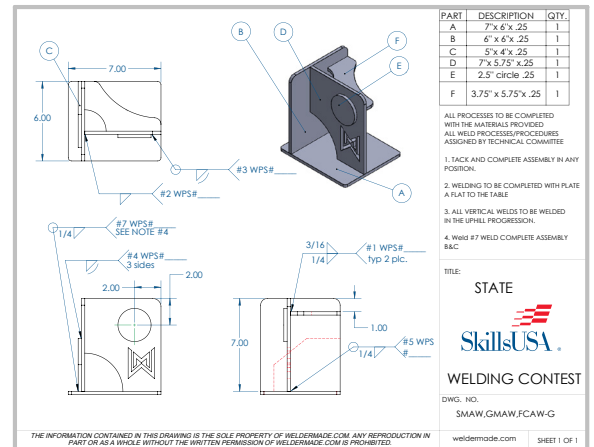

Steel Project

'A'=YES it meets this criteria
'B' = NO it does NOT meet this criteria
FCAW FINAL

Assembly
Questions

1	Has surface slag, spatter, and smoke been removed from all of the joints and surrounding areas?
2	Is the Project Assembled In Accordance to the Drawing?
3	Does the overall workmanship display consistency among all welds? (ALL WELDS MUST BE GENERALLY CONSISTENT WITH NO SIGNIFICANT DISCONTUNITIUES)
4	Weld # _____ Crater Cross Section. All craters should be filled to provide the specified weld size, except for the end of intermittent fillet welds outside of their effective length. Are the weld craters completely filled to the weld size?
5	Weld # _____ Overall bead width not to exceed 1/16 in. variation in width (from max to min) for any weld face. Does the weld meet this requirement?
6	Weld # _____ Porosity. No visible porosity is acceptable, Does the Weld Meet this Requirement?
7	Weld # _____ Undercut. Not to exceed 1/32 in depth for a total accumulated length of 1/2in. Does the weld meet this requirement?
8	Weld # _____ Undersized Welds. Weld Size not to be larger by anything greater than 1/16 in. anywhere along the weld length and no smaller than specified on the drawing. Does the weld size meet this requirement?
9	Weld # _____ Weld Profiles. Fillet welds can be slightly concave, flat, or slightly convex with the crown not to exceed 3/32 in. above flat Groove Welds can be flush with an even crown not to exceed 3/32 in. Does this weld meet this requirement?
10	Weld # _____ Weld/Base metal Fusion. Complete fusion shall exist between base and weld metal. Does the weld display complete fusion with no cold lap?
11	Weld # _____ There shall be no Arc Marks outside the weld area. Does the weld meet this requirement?
12	All other Fillet Welds Undersized Welds. Weld Size not to be larger by anything greater than 1/16 in. anywhere along the weld length and no smaller than specified on the drawing. Do all remaining fillet welds meet this requirement?

NOTE: This Final criteria is designed to follow AWD D1.1 table 6.1 Visual inspection criteria as a start, but much more difficult. Picking three top performing welds requires that the evaluation is more strict than code. We hope to eventually add tiers of quality to these questions that fall in line with the World Skills Welding Scoring Criteria which is extremely strict to be able to separate near perfect welds to determine a rank. In the future as competition welding performance improves over time these questions will evolve.



Was there a safety infraction? BE SURE TO NOTE
The Competitor Number and Explain the safety
violation on the Safety Infraction Sheet.

NOTE: This IPJ (in-process judging) is designed to be a random check as 1 inspector walks down the line 2 times, and at the moment they are walking by each station, they check this criteria. This models on the job random QA inspection to ensure welding procedures are followed.

'A'=YES meets criteria
'B'=NO. Does Not meet Criteria
FCAW IPJ

1	Spot Check #1 Is the voltage within range specified on the WPS?
2	Spot Check #1 Is the gas flow rate within the range specified on the WPS?
3	Spot Check #1 Is the wire feed speed within range specified on the WPS?
4	Spot Check #2 Is the voltage within range specified on the WPS?
5	Spot Check #2 Is the gas flow rate within the range specified on the WPS?
6	Spot Check #2 Is the wire feed speed within range specified on the WPS?



Was there a safety infraction? BE SURE TO NOTE The Competitor Number and Explain the safety violation on the Safety Infraction Sheet.

NOTE: This IPJ (in-process judging) is designed to be a random check as 1 inspector walks down the line 2 times, and at the moment they are walking by each station, they check this criteria. This models on the job random QA inspection to ensure welding procedures are followed.

'A'=YES it meets this criteria
'B' = NO it does NOT meet this criteria
GMAW FINAL

Assembly
Questions

1	Has surface slag, spatter, and smoke been removed from all of the joints and surrounding areas?
2	Is the Project Assembled In Accordance to the Drawing?
3	Does the overall workmanship display consistency among all welds? (ALL WELDS MUST BE GENERALLY CONSISTENT WITH NO SIGNIFICANT DISCONTUNITIES)
4	Weld # _____ Crater Cross Section. All craters should be filled to provide the specified weld size, except for the end of intermittent fillet welds outside of their effective length. Are the weld craters completely filled to the weld size?
5	Weld # _____ Overall bead width not to exceed 1/16 in. variation in width (from max to min) for any weld face. Does the weld meet this requirement?
6	Weld # _____ Porosity. No visible porosity is acceptable, Does the Weld Meet this Requirement?
7	Weld # _____ Undercut. Not to exceed 1/32 in depth for a total accumulated length of 1/2in. Does the weld meet this requirement?
8	Weld # _____ Undersized Welds. Weld Size not to be larger by anything greater than 1/16 in. anywhere along the weld length and no smaller than specified on the drawing. Does the weld size meet this requirement?
9	Weld # _____ Weld Profiles. Fillet welds can be slightly concave, flat, or slightly convex with the crown not to exceed 3/32 in. above flat. Groove Welds can be flush with an even crown not to exceed 3/32 in. Does this weld meet this requirement?
10	Weld # _____ Weld/Base metal Fusion. Complete fusion shall exist between base and weld metal. Does the weld display complete fusion with no cold lap?
11	Weld # _____ There shall be no Arc Marks outside the weld area. Does the weld meet this requirement?
12	All other Fillet Welds Undersized Welds. Weld Size not to be larger by anything greater than 1/16 in. anywhere along the weld length and no smaller than specified on the drawing. Do all remaining fillet welds meet this requirement?

NOTE: This Final criteria is designed to follow AWD D1-1 table 6.1 Visual inspection criteria as a start, but much more difficult. Picking three top performing welds requires that the evaluation is more strict than code. We hope to eventually add tiers of quality to these questions that fall in line with the World Skills Welding Scoring Criteria which is extremely strict to be able to separate near perfect welds to determine a rank. In the future as competition welding performance improves over time these questions will evolve.



Was there a safety infraction? BE SURE TO NOTE
The Competitor Number and Explain the safety
violation on the Safety Infraction Sheet.

NOTE: This IPJ (in-process judging) is designed to be a random check as 1 inspector walks down the line 2 times, and at the moment they are walking by each station, they check this criteria. This models on the job random QA inspection to ensure welding procedures are followed.

'A'=YES meets criteria

'B'=NO. Does Not meet Criteria

GMAW IPJ

1	Spot Check #1 Is the voltage within range specified on the WPS?
2	Spot Check #1 Is the gas flow rate within the range specified on the WPS?
3	Spot Check #1 Is the wire feed speed within range specified on the WPS?
4	Spot Check #2 Is the voltage within range specified on the WPS?
5	Spot Check #2 Is the gas flow rate within the range specified on the WPS?
6	Spot Check #2 Is the wire feed speed within range specified on the WPS?



Was there a safety infraction? BE SURE TO NOTE The Competitor Number and Explain the safety violation on the Safety Infraction Sheet.

Name Class Quiz **GTAW**

Student ZipGrade ID

0	<input type="radio"/>	<input type="radio"/>	<input type="radio"/>	<input type="radio"/>	<input type="radio"/>	<input type="radio"/>	<input type="radio"/>	<input type="radio"/>	<input type="radio"/>
1	<input type="radio"/>	<input type="radio"/>	<input type="radio"/>	<input type="radio"/>	<input type="radio"/>	<input type="radio"/>	<input type="radio"/>	<input type="radio"/>	<input type="radio"/>
2	<input type="radio"/>	<input type="radio"/>	<input type="radio"/>	<input type="radio"/>	<input type="radio"/>	<input type="radio"/>	<input type="radio"/>	<input type="radio"/>	<input type="radio"/>
3	<input type="radio"/>	<input type="radio"/>	<input type="radio"/>	<input type="radio"/>	<input type="radio"/>	<input type="radio"/>	<input type="radio"/>	<input type="radio"/>	<input type="radio"/>
4	<input type="radio"/>	<input type="radio"/>	<input type="radio"/>	<input type="radio"/>	<input type="radio"/>	<input type="radio"/>	<input type="radio"/>	<input type="radio"/>	<input type="radio"/>
5	<input type="radio"/>	<input type="radio"/>	<input type="radio"/>	<input type="radio"/>	<input type="radio"/>	<input type="radio"/>	<input type="radio"/>	<input type="radio"/>	<input type="radio"/>
6	<input type="radio"/>	<input type="radio"/>	<input type="radio"/>	<input type="radio"/>	<input type="radio"/>	<input type="radio"/>	<input type="radio"/>	<input type="radio"/>	<input type="radio"/>
7	<input type="radio"/>	<input type="radio"/>	<input type="radio"/>	<input type="radio"/>	<input type="radio"/>	<input type="radio"/>	<input type="radio"/>	<input type="radio"/>	<input type="radio"/>
8	<input type="radio"/>	<input type="radio"/>	<input type="radio"/>	<input type="radio"/>	<input type="radio"/>	<input type="radio"/>	<input type="radio"/>	<input type="radio"/>	<input type="radio"/>
9	<input type="radio"/>	<input type="radio"/>	<input type="radio"/>	<input type="radio"/>	<input type="radio"/>	<input type="radio"/>	<input type="radio"/>	<input type="radio"/>	<input type="radio"/>

Key

A	<input type="radio"/>
B	<input type="radio"/>
C	<input type="radio"/>
D	<input type="radio"/>
E	<input type="radio"/>

<input type="radio"/>	A	<input type="radio"/>	B	<input type="radio"/>	C	<input type="radio"/>	D	<input type="radio"/>	E	<input type="radio"/>	A	<input type="radio"/>	B	<input type="radio"/>	C	<input type="radio"/>	D	<input type="radio"/>	E
41	<input type="radio"/>	<input type="radio"/>	<input type="radio"/>	<input type="radio"/>	<input type="radio"/>	<input type="radio"/>	<input type="radio"/>	<input type="radio"/>	<input type="radio"/>	71	<input type="radio"/>	<input type="radio"/>	<input type="radio"/>	<input type="radio"/>	<input type="radio"/>	<input type="radio"/>	<input type="radio"/>	<input type="radio"/>	<input type="radio"/>
42	<input type="radio"/>	<input type="radio"/>	<input type="radio"/>	<input type="radio"/>	<input type="radio"/>	<input type="radio"/>	<input type="radio"/>	<input type="radio"/>	<input type="radio"/>	72	<input type="radio"/>	<input type="radio"/>	<input type="radio"/>	<input type="radio"/>	<input type="radio"/>	<input type="radio"/>	<input type="radio"/>	<input type="radio"/>	<input type="radio"/>
43	<input type="radio"/>	<input type="radio"/>	<input type="radio"/>	<input type="radio"/>	<input type="radio"/>	<input type="radio"/>	<input type="radio"/>	<input type="radio"/>	<input type="radio"/>	73	<input type="radio"/>	<input type="radio"/>	<input type="radio"/>	<input type="radio"/>	<input type="radio"/>	<input type="radio"/>	<input type="radio"/>	<input type="radio"/>	<input type="radio"/>
44	<input type="radio"/>	<input type="radio"/>	<input type="radio"/>	<input type="radio"/>	<input type="radio"/>	<input type="radio"/>	<input type="radio"/>	<input type="radio"/>	<input type="radio"/>	74	<input type="radio"/>	<input type="radio"/>	<input type="radio"/>	<input type="radio"/>	<input type="radio"/>	<input type="radio"/>	<input type="radio"/>	<input type="radio"/>	<input type="radio"/>
45	<input type="radio"/>	<input type="radio"/>	<input type="radio"/>	<input type="radio"/>	<input type="radio"/>	<input type="radio"/>	<input type="radio"/>	<input type="radio"/>	<input type="radio"/>	75	<input type="radio"/>	<input type="radio"/>	<input type="radio"/>	<input type="radio"/>	<input type="radio"/>	<input type="radio"/>	<input type="radio"/>	<input type="radio"/>	<input type="radio"/>
46	<input type="radio"/>	<input type="radio"/>	<input type="radio"/>	<input type="radio"/>	<input type="radio"/>	<input type="radio"/>	<input type="radio"/>	<input type="radio"/>	<input type="radio"/>	76	<input type="radio"/>	<input type="radio"/>	<input type="radio"/>	<input type="radio"/>	<input type="radio"/>	<input type="radio"/>	<input type="radio"/>	<input type="radio"/>	<input type="radio"/>
47	<input type="radio"/>	<input type="radio"/>	<input type="radio"/>	<input type="radio"/>	<input type="radio"/>	<input type="radio"/>	<input type="radio"/>	<input type="radio"/>	<input type="radio"/>	77	<input type="radio"/>	<input type="radio"/>	<input type="radio"/>	<input type="radio"/>	<input type="radio"/>	<input type="radio"/>	<input type="radio"/>	<input type="radio"/>	<input type="radio"/>
48	<input type="radio"/>	<input type="radio"/>	<input type="radio"/>	<input type="radio"/>	<input type="radio"/>	<input type="radio"/>	<input type="radio"/>	<input type="radio"/>	<input type="radio"/>	78	<input type="radio"/>	<input type="radio"/>	<input type="radio"/>	<input type="radio"/>	<input type="radio"/>	<input type="radio"/>	<input type="radio"/>	<input type="radio"/>	<input type="radio"/>
49	<input type="radio"/>	<input type="radio"/>	<input type="radio"/>	<input type="radio"/>	<input type="radio"/>	<input type="radio"/>	<input type="radio"/>	<input type="radio"/>	<input type="radio"/>	79	<input type="radio"/>	<input type="radio"/>	<input type="radio"/>	<input type="radio"/>	<input type="radio"/>	<input type="radio"/>	<input type="radio"/>	<input type="radio"/>	<input type="radio"/>
50	<input type="radio"/>	<input type="radio"/>	<input type="radio"/>	<input type="radio"/>	<input type="radio"/>	<input type="radio"/>	<input type="radio"/>	<input type="radio"/>	<input type="radio"/>	80	<input type="radio"/>	<input type="radio"/>	<input type="radio"/>	<input type="radio"/>	<input type="radio"/>	<input type="radio"/>	<input type="radio"/>	<input type="radio"/>	<input type="radio"/>
<input type="radio"/>	A	<input type="radio"/>	B	<input type="radio"/>	C	<input type="radio"/>	D	<input type="radio"/>	E	<input type="radio"/>	A	<input type="radio"/>	B	<input type="radio"/>	C	<input type="radio"/>	D	<input type="radio"/>	E
1	<input type="radio"/>	<input type="radio"/>	<input type="radio"/>	<input type="radio"/>	<input type="radio"/>	<input type="radio"/>	<input type="radio"/>	<input type="radio"/>	<input type="radio"/>	21	<input type="radio"/>	<input type="radio"/>	<input type="radio"/>	<input type="radio"/>	<input type="radio"/>	<input type="radio"/>	<input type="radio"/>	<input type="radio"/>	<input type="radio"/>
2	<input type="radio"/>	<input type="radio"/>	<input type="radio"/>	<input type="radio"/>	<input type="radio"/>	<input type="radio"/>	<input type="radio"/>	<input type="radio"/>	<input type="radio"/>	22	<input type="radio"/>	<input type="radio"/>	<input type="radio"/>	<input type="radio"/>	<input type="radio"/>	<input type="radio"/>	<input type="radio"/>	<input type="radio"/>	<input type="radio"/>
3	<input type="radio"/>	<input type="radio"/>	<input type="radio"/>	<input type="radio"/>	<input type="radio"/>	<input type="radio"/>	<input type="radio"/>	<input type="radio"/>	<input type="radio"/>	23	<input type="radio"/>	<input type="radio"/>	<input type="radio"/>	<input type="radio"/>	<input type="radio"/>	<input type="radio"/>	<input type="radio"/>	<input type="radio"/>	<input type="radio"/>
4	<input type="radio"/>	<input type="radio"/>	<input type="radio"/>	<input type="radio"/>	<input type="radio"/>	<input type="radio"/>	<input type="radio"/>	<input type="radio"/>	<input type="radio"/>	24	<input type="radio"/>	<input type="radio"/>	<input type="radio"/>	<input type="radio"/>	<input type="radio"/>	<input type="radio"/>	<input type="radio"/>	<input type="radio"/>	<input type="radio"/>
5	<input type="radio"/>	<input type="radio"/>	<input type="radio"/>	<input type="radio"/>	<input type="radio"/>	<input type="radio"/>	<input type="radio"/>	<input type="radio"/>	<input type="radio"/>	25	<input type="radio"/>	<input type="radio"/>	<input type="radio"/>	<input type="radio"/>	<input type="radio"/>	<input type="radio"/>	<input type="radio"/>	<input type="radio"/>	<input type="radio"/>
6	<input type="radio"/>	<input type="radio"/>	<input type="radio"/>	<input type="radio"/>	<input type="radio"/>	<input type="radio"/>	<input type="radio"/>	<input type="radio"/>	<input type="radio"/>	26	<input type="radio"/>	<input type="radio"/>	<input type="radio"/>	<input type="radio"/>	<input type="radio"/>	<input type="radio"/>	<input type="radio"/>	<input type="radio"/>	<input type="radio"/>
7	<input type="radio"/>	<input type="radio"/>	<input type="radio"/>	<input type="radio"/>	<input type="radio"/>	<input type="radio"/>	<input type="radio"/>	<input type="radio"/>	<input type="radio"/>	27	<input type="radio"/>	<input type="radio"/>	<input type="radio"/>	<input type="radio"/>	<input type="radio"/>	<input type="radio"/>	<input type="radio"/>	<input type="radio"/>	<input type="radio"/>
8	<input type="radio"/>	<input type="radio"/>	<input type="radio"/>	<input type="radio"/>	<input type="radio"/>	<input type="radio"/>	<input type="radio"/>	<input type="radio"/>	<input type="radio"/>	28	<input type="radio"/>	<input type="radio"/>	<input type="radio"/>	<input type="radio"/>	<input type="radio"/>	<input type="radio"/>	<input type="radio"/>	<input type="radio"/>	<input type="radio"/>
9	<input type="radio"/>	<input type="radio"/>	<input type="radio"/>	<input type="radio"/>	<input type="radio"/>	<input type="radio"/>	<input type="radio"/>	<input type="radio"/>	<input type="radio"/>	29	<input type="radio"/>	<input type="radio"/>	<input type="radio"/>	<input type="radio"/>	<input type="radio"/>	<input type="radio"/>	<input type="radio"/>	<input type="radio"/>	<input type="radio"/>
10	<input type="radio"/>	<input type="radio"/>	<input type="radio"/>	<input type="radio"/>	<input type="radio"/>	<input type="radio"/>	<input type="radio"/>	<input type="radio"/>	<input type="radio"/>	30	<input type="radio"/>	<input type="radio"/>	<input type="radio"/>	<input type="radio"/>	<input type="radio"/>	<input type="radio"/>	<input type="radio"/>	<input type="radio"/>	<input type="radio"/>
<input type="radio"/>	A	<input type="radio"/>	B	<input type="radio"/>	C	<input type="radio"/>	D	<input type="radio"/>	E	<input type="radio"/>	A	<input type="radio"/>	B	<input type="radio"/>	C	<input type="radio"/>	D	<input type="radio"/>	E
11	<input type="radio"/>	<input type="radio"/>	<input type="radio"/>	<input type="radio"/>	<input type="radio"/>	<input type="radio"/>	<input type="radio"/>	<input type="radio"/>	<input type="radio"/>	31	<input type="radio"/>	<input type="radio"/>	<input type="radio"/>	<input type="radio"/>	<input type="radio"/>	<input type="radio"/>	<input type="radio"/>	<input type="radio"/>	<input type="radio"/>
12	<input type="radio"/>	<input type="radio"/>	<input type="radio"/>	<input type="radio"/>	<input type="radio"/>	<input type="radio"/>	<input type="radio"/>	<input type="radio"/>	<input type="radio"/>	32	<input type="radio"/>	<input type="radio"/>	<input type="radio"/>	<input type="radio"/>	<input type="radio"/>	<input type="radio"/>	<input type="radio"/>	<input type="radio"/>	<input type="radio"/>
13	<input type="radio"/>	<input type="radio"/>	<input type="radio"/>	<input type="radio"/>	<input type="radio"/>	<input type="radio"/>	<input type="radio"/>	<input type="radio"/>	<input type="radio"/>	33	<input type="radio"/>	<input type="radio"/>	<input type="radio"/>	<input type="radio"/>	<input type="radio"/>	<input type="radio"/>	<input type="radio"/>	<input type="radio"/>	<input type="radio"/>
14	<input type="radio"/>	<input type="radio"/>	<input type="radio"/>	<input type="radio"/>	<input type="radio"/>	<input type="radio"/>	<input type="radio"/>	<input type="radio"/>	<input type="radio"/>	34	<input type="radio"/>	<input type="radio"/>	<input type="radio"/>	<input type="radio"/>	<input type="radio"/>	<input type="radio"/>	<input type="radio"/>	<input type="radio"/>	<input type="radio"/>
15	<input type="radio"/>	<input type="radio"/>	<input type="radio"/>	<input type="radio"/>	<input type="radio"/>	<input type="radio"/>	<input type="radio"/>	<input type="radio"/>	<input type="radio"/>	35	<input type="radio"/>	<input type="radio"/>	<input type="radio"/>	<input type="radio"/>	<input type="radio"/>	<input type="radio"/>	<input type="radio"/>	<input type="radio"/>	<input type="radio"/>
16	<input type="radio"/>	<input type="radio"/>	<input type="radio"/>	<input type="radio"/>	<input type="radio"/>	<input type="radio"/>	<input type="radio"/>	<input type="radio"/>	<input type="radio"/>	36	<input type="radio"/>	<input type="radio"/>	<input type="radio"/>	<input type="radio"/>	<input type="radio"/>	<input type="radio"/>	<input type="radio"/>	<input type="radio"/>	<input type="radio"/>
17	<input type="radio"/>	<input type="radio"/>	<input type="radio"/>	<input type="radio"/>	<input type="radio"/>	<input type="radio"/>	<input type="radio"/>	<input type="radio"/>	<input type="radio"/>	37	<input type="radio"/>	<input type="radio"/>	<input type="radio"/>	<input type="radio"/>	<input type="radio"/>	<input type="radio"/>	<input type="radio"/>	<input type="radio"/>	<input type="radio"/>
18	<input type="radio"/>	<input type="radio"/>	<input type="radio"/>	<input type="radio"/>	<input type="radio"/>	<input type="radio"/>	<input type="radio"/>	<input type="radio"/>	<input type="radio"/>	38	<input type="radio"/>	<input type="radio"/>	<input type="radio"/>	<input type="radio"/>	<input type="radio"/>	<input type="radio"/>	<input type="radio"/>	<input type="radio"/>	<input type="radio"/>
19	<input type="radio"/>	<input type="radio"/>	<input type="radio"/>	<input type="radio"/>	<input type="radio"/>	<input type="radio"/>	<input type="radio"/>	<input type="radio"/>	<input type="radio"/>	39	<input type="radio"/>	<input type="radio"/>	<input type="radio"/>	<input type="radio"/>	<input type="radio"/>	<input type="radio"/>	<input type="radio"/>	<input type="radio"/>	<input type="radio"/>
20	<input type="radio"/>	<input type="radio"/>	<input type="radio"/>	<input type="radio"/>	<input type="radio"/>	<input type="radio"/>	<input type="radio"/>	<input type="radio"/>	<input type="radio"/>	40	<input type="radio"/>	<input type="radio"/>	<input type="radio"/>	<input type="radio"/>	<input type="radio"/>	<input type="radio"/>	<input type="radio"/>	<input type="radio"/>	<input type="radio"/>
										51	<input type="radio"/>	<input type="radio"/>	<input type="radio"/>	<input type="radio"/>	<input type="radio"/>	<input type="radio"/>	<input type="radio"/>	<input type="radio"/>	<input type="radio"/>
										52	<input type="radio"/>	<input type="radio"/>	<input type="radio"/>	<input type="radio"/>	<input type="radio"/>	<input type="radio"/>	<input type="radio"/>	<input type="radio"/>	<input type="radio"/>
										53	<input type="radio"/>	<input type="radio"/>	<input type="radio"/>	<input type="radio"/>	<input type="radio"/>	<input type="radio"/>	<input type="radio"/>	<input type="radio"/>	<input type="radio"/>
										54	<input type="radio"/>	<input type="radio"/>	<input type="radio"/>	<input type="radio"/>	<input type="radio"/>	<input type="radio"/>	<input type="radio"/>	<input type="radio"/>	<input type="radio"/>
										55	<input type="radio"/>	<input type="radio"/>	<input type="radio"/>	<input type="radio"/>	<input type="radio"/>	<input type="radio"/>	<input type="radio"/>	<input type="radio"/>	<input type="radio"/>
										56	<input type="radio"/>	<input type="radio"/>	<input type="radio"/>	<input type="radio"/>	<input type="radio"/>	<input type="radio"/>	<input type="radio"/>	<input type="radio"/>	<input type="radio"/>
										57	<input type="radio"/>	<input type="radio"/>	<input type="radio"/>	<input type="radio"/>	<input type="radio"/>	<input type="radio"/>	<input type="radio"/>	<input type="radio"/>	<input type="radio"/>
										58	<input type="radio"/>	<input type="radio"/>	<input type="radio"/>	<input type="radio"/>	<input type="radio"/>	<input type="radio"/>	<input type="radio"/>	<input type="radio"/>	<input type="radio"/>
										59	<input type="radio"/>	<input type="radio"/>	<input type="radio"/>	<input type="radio"/>	<input type="radio"/>	<input type="radio"/>	<input type="radio"/>	<input type="radio"/>	<input type="radio"/>
										60	<input type="radio"/>	<input type="radio"/>	<input type="radio"/>	<input type="radio"/>	<input type="radio"/>	<input type="radio"/>	<input type="radio"/>	<input type="radio"/>	<input type="radio"/>
										61	<input type="radio"/>	<input type="radio"/>	<input type="radio"/>	<input type="radio"/>	<input type="radio"/>	<input type="radio"/>	<input type="radio"/>	<input type="radio"/>	<input type="radio"/>
										62	<input type="radio"/>	<input type="radio"/>	<input type="radio"/>	<input type="radio"/>	<input type="radio"/>	<input type="radio"/>	<input type="radio"/>	<input type="radio"/>	<input type="radio"/>
										63	<input type="radio"/>	<input type="radio"/>	<input type="radio"/>	<input type="radio"/>	<input type="radio"/>	<input type="radio"/>	<input type="radio"/>	<input type="radio"/>	<input type="radio"/>
										64	<input type="radio"/>	<input type="radio"/>	<input type="radio"/>	<input type="radio"/>	<input type="radio"/>	<input type="radio"/>	<input type="radio"/>	<input type="radio"/>	<input type="radio"/>
										65	<input type="radio"/>	<input type="radio"/>	<input type="radio"/>	<input type="radio"/>	<input type="radio"/>	<input type="radio"/>	<input type="radio"/>	<input type="radio"/>	<input type="radio"/>
										66	<input type="radio"/>	<input type="radio"/>	<input type="radio"/>	<input type="radio"/>	<input type="radio"/>	<input type="radio"/>	<input type="radio"/>	<input type="radio"/>	<input type="radio"/>
										67	<input type="radio"/>	<input type="radio"/>	<input type="radio"/>	<input type="radio"/>	<input type="radio"/>	<input type="radio"/>	<input type="radio"/>	<input type="radio"/>	<input type="radio"/>
										68	<input type="radio"/>	<input type="radio"/>	<input type="radio"/>	<input type="radio"/>	<input type="radio"/>	<input type="radio"/>	<input type="radio"/>	<input type="radio"/>	<input type="radio"/>
										69	<input type="radio"/>	<input type="radio"/>	<input type="radio"/>	<input type="radio"/>	<input type="radio"/>	<input type="radio"/>	<input type="radio"/>	<input type="radio"/>	<input type="radio"/>
										70	<input type="radio"/>	<input type="radio"/>	<input type="radio"/>	<input type="radio"/>	<input type="radio"/>	<input type="radio"/>	<input type="radio"/>	<input type="radio"/>	<input type="radio"/>
										100	<input type="radio"/>	<input type="radio"/>	<input type="radio"/>	<input type="radio"/>	<input type="radio"/>	<input type="radio"/>	<input type="radio"/>	<input type="radio"/>	<input type="radio"/>

- Do not fold or bend sheet
- Erase mistakes completely

- Use pencil or dark pen
- Fill circle fully



'A'=YES it mees this criteria
'B' = NO it does NOT meet this criteria
GTAW FINAL

NOTE: This Final criteria is designed to follow AWD D1.1 table 6.1 Visual inspection criteria as a start, but much more difficult. Picking three top performing welds requires that the evaluation is more strict than code. We hope to eventually add tiers of quality to these questions that fall in line with the World Skills Welding Scoring Criteria which is extremely strict to be able to separate near perfect welds to determine a rank. In the future as competition welding performance improves over time these questions will evolve. At the National championships, we see too many GTAW projects in pieces on the turn in table. This GTAW scoring rubric emphasizes completion. Once the trend of incomplete GTAW projects changes, this criteria will stress less on the completion of welds.

Assembly
Questions

1	Is the Project Assembled In Accordance to the Drawing?
2	Was the order of operations followed?
3	The GTAW Project should show no post weld wire brushing, does this project display no post weld wire brushing?
4	Weld # _____ Placed in the proper Location?
5	Weld # _____ Proper Size and Length?
6	Weld # _____ Overall bead width not to exceed 1/32 in. variation in width (from max to min) for any weld face. Does the weld meet this requirement?
7	Are all present welds free from porosity? No visible porosity is acceptable, Do the Welds Meet this Requirement?
8	Weld # _____ Crater Cross Section. All craters should be filled to provide the specified weld size, except for the end of intermittent fillet welds outside of their effective length. Are the weld craters completely filled to the weld size?
9	Weld # _____ Weld/Base metal Fusion. Complete fusion shall exist between base and weld metal. Does the weld display complete fusion with no cold lap?
10	Weld # _____ Weld Profiles. Fillet welds can be flat, or slightly convex with the crown not to exceed 1/16 in. above flush. Groove Welds can be flush with an even crown not to exceed 3/32 in. Does this weld meet this requirement?
11	Did Welder complete _____ Number of welds or more?
12	FOR PROJECTS THAT HAVE _____ OR MORE WELDS COMPLETED (For projects with less weld, or it has been wirebrushed, the answer is NO. "Touchdowns" are when the tungsten is touched to the workpiece or the filler metal and an indication can be visible as long as no post wirebrushing is performed. Is the project free from any "touchdowns"?



Was their a safety infraction? BE SURE TO NOTE The Competitor Number and Explain the safety violation on the Safety Infraction Sheet.

'A'=YES meets criteria
'B'=NO. Does Not meet Criteria

NOTE: This IPJ (in-process judging) is designed to be a random check as 1 inspector walks down the line 2 times, and at the moment they are walking by each station, they check this criteria. This models on the job random QA inspection to ensure welding procedures are followed.

GTAW IPJ

1	Spot Check #1 Is the amperage within range specified on the WPS?
2	Spot Check #1 Is the gas Flow rate within range specified on the WPS?
3	Spot Check #2 Is the amperage within range specified on the WPS?
4	Spot Check #2 Is the welding being performed in the correct position?



Was there a safety infraction? BE SURE TO NOTE The Competitor Number and Explain the safety violation on the Safety Infraction Sheet.

Name Class Quiz **SMAW**

Student ZipGrade ID

--	--	--	--	--	--	--	--	--	--

Key

A	<input type="radio"/>
B	<input type="radio"/>
C	<input type="radio"/>
D	<input type="radio"/>
E	<input type="radio"/>

	<input type="radio"/>	A	<input type="radio"/>	B	<input type="radio"/>	C	<input type="radio"/>	D	<input type="radio"/>	E	<input type="radio"/>	A	<input type="radio"/>	B	<input type="radio"/>	C	<input type="radio"/>	D	<input type="radio"/>	E	
41	<input type="radio"/>		<input type="radio"/>		<input type="radio"/>		<input type="radio"/>		<input type="radio"/>		<input type="radio"/>	71	<input type="radio"/>		<input type="radio"/>		<input type="radio"/>		<input type="radio"/>		<input type="radio"/>
42	<input type="radio"/>		<input type="radio"/>		<input type="radio"/>		<input type="radio"/>		<input type="radio"/>		<input type="radio"/>	72	<input type="radio"/>		<input type="radio"/>		<input type="radio"/>		<input type="radio"/>		<input type="radio"/>
43	<input type="radio"/>		<input type="radio"/>		<input type="radio"/>		<input type="radio"/>		<input type="radio"/>		<input type="radio"/>	73	<input type="radio"/>		<input type="radio"/>		<input type="radio"/>		<input type="radio"/>		<input type="radio"/>
44	<input type="radio"/>		<input type="radio"/>		<input type="radio"/>		<input type="radio"/>		<input type="radio"/>		<input type="radio"/>	74	<input type="radio"/>		<input type="radio"/>		<input type="radio"/>		<input type="radio"/>		<input type="radio"/>
45	<input type="radio"/>		<input type="radio"/>		<input type="radio"/>		<input type="radio"/>		<input type="radio"/>		<input type="radio"/>	75	<input type="radio"/>		<input type="radio"/>		<input type="radio"/>		<input type="radio"/>		<input type="radio"/>
46	<input type="radio"/>		<input type="radio"/>		<input type="radio"/>		<input type="radio"/>		<input type="radio"/>		<input type="radio"/>	76	<input type="radio"/>		<input type="radio"/>		<input type="radio"/>		<input type="radio"/>		<input type="radio"/>
47	<input type="radio"/>		<input type="radio"/>		<input type="radio"/>		<input type="radio"/>		<input type="radio"/>		<input type="radio"/>	77	<input type="radio"/>		<input type="radio"/>		<input type="radio"/>		<input type="radio"/>		<input type="radio"/>
48	<input type="radio"/>		<input type="radio"/>		<input type="radio"/>		<input type="radio"/>		<input type="radio"/>		<input type="radio"/>	78	<input type="radio"/>		<input type="radio"/>		<input type="radio"/>		<input type="radio"/>		<input type="radio"/>
49	<input type="radio"/>		<input type="radio"/>		<input type="radio"/>		<input type="radio"/>		<input type="radio"/>		<input type="radio"/>	79	<input type="radio"/>		<input type="radio"/>		<input type="radio"/>		<input type="radio"/>		<input type="radio"/>
50	<input type="radio"/>		<input type="radio"/>		<input type="radio"/>		<input type="radio"/>		<input type="radio"/>		<input type="radio"/>	80	<input type="radio"/>		<input type="radio"/>		<input type="radio"/>		<input type="radio"/>		<input type="radio"/>
	<input type="radio"/>	A	<input type="radio"/>	<input type="radio"/>	<input type="radio"/>	<input type="radio"/>	<input type="radio"/>	<input type="radio"/>	<input type="radio"/>	<input type="radio"/>	<input type="radio"/>		<input type="radio"/>	A	<input type="radio"/>	<input type="radio"/>	<input type="radio"/>	<input type="radio"/>	<input type="radio"/>	<input type="radio"/>	<input type="radio"/>
1	<input type="radio"/>		<input type="radio"/>		<input type="radio"/>		<input type="radio"/>		<input type="radio"/>		<input type="radio"/>	21	<input type="radio"/>		<input type="radio"/>		<input type="radio"/>		<input type="radio"/>		<input type="radio"/>
2	<input type="radio"/>		<input type="radio"/>		<input type="radio"/>		<input type="radio"/>		<input type="radio"/>		<input type="radio"/>	22	<input type="radio"/>		<input type="radio"/>		<input type="radio"/>		<input type="radio"/>		<input type="radio"/>
3	<input type="radio"/>		<input type="radio"/>		<input type="radio"/>		<input type="radio"/>		<input type="radio"/>		<input type="radio"/>	23	<input type="radio"/>		<input type="radio"/>		<input type="radio"/>		<input type="radio"/>		<input type="radio"/>
4	<input type="radio"/>		<input type="radio"/>		<input type="radio"/>		<input type="radio"/>		<input type="radio"/>		<input type="radio"/>	24	<input type="radio"/>		<input type="radio"/>		<input type="radio"/>		<input type="radio"/>		<input type="radio"/>
5	<input type="radio"/>		<input type="radio"/>		<input type="radio"/>		<input type="radio"/>		<input type="radio"/>		<input type="radio"/>	25	<input type="radio"/>		<input type="radio"/>		<input type="radio"/>		<input type="radio"/>		<input type="radio"/>
6	<input type="radio"/>		<input type="radio"/>		<input type="radio"/>		<input type="radio"/>		<input type="radio"/>		<input type="radio"/>	26	<input type="radio"/>		<input type="radio"/>		<input type="radio"/>		<input type="radio"/>		<input type="radio"/>
7	<input type="radio"/>		<input type="radio"/>		<input type="radio"/>		<input type="radio"/>		<input type="radio"/>		<input type="radio"/>	27	<input type="radio"/>		<input type="radio"/>		<input type="radio"/>		<input type="radio"/>		<input type="radio"/>
8	<input type="radio"/>		<input type="radio"/>		<input type="radio"/>		<input type="radio"/>		<input type="radio"/>		<input type="radio"/>	28	<input type="radio"/>		<input type="radio"/>		<input type="radio"/>		<input type="radio"/>		<input type="radio"/>
9	<input type="radio"/>		<input type="radio"/>		<input type="radio"/>		<input type="radio"/>		<input type="radio"/>		<input type="radio"/>	29	<input type="radio"/>		<input type="radio"/>		<input type="radio"/>		<input type="radio"/>		<input type="radio"/>
10	<input type="radio"/>		<input type="radio"/>		<input type="radio"/>		<input type="radio"/>		<input type="radio"/>		<input type="radio"/>	30	<input type="radio"/>		<input type="radio"/>		<input type="radio"/>		<input type="radio"/>		<input type="radio"/>
	<input type="radio"/>	A	<input type="radio"/>	<input type="radio"/>	<input type="radio"/>	<input type="radio"/>	<input type="radio"/>	<input type="radio"/>	<input type="radio"/>	<input type="radio"/>	<input type="radio"/>		<input type="radio"/>	A	<input type="radio"/>	<input type="radio"/>	<input type="radio"/>	<input type="radio"/>	<input type="radio"/>	<input type="radio"/>	<input type="radio"/>
11	<input type="radio"/>		<input type="radio"/>		<input type="radio"/>		<input type="radio"/>		<input type="radio"/>		<input type="radio"/>	31	<input type="radio"/>		<input type="radio"/>		<input type="radio"/>		<input type="radio"/>		<input type="radio"/>
12	<input type="radio"/>		<input type="radio"/>		<input type="radio"/>		<input type="radio"/>		<input type="radio"/>		<input type="radio"/>	32	<input type="radio"/>		<input type="radio"/>		<input type="radio"/>		<input type="radio"/>		<input type="radio"/>
13	<input type="radio"/>		<input type="radio"/>		<input type="radio"/>		<input type="radio"/>		<input type="radio"/>		<input type="radio"/>	33	<input type="radio"/>		<input type="radio"/>		<input type="radio"/>		<input type="radio"/>		<input type="radio"/>
14	<input type="radio"/>		<input type="radio"/>		<input type="radio"/>		<input type="radio"/>		<input type="radio"/>		<input type="radio"/>	34	<input type="radio"/>		<input type="radio"/>		<input type="radio"/>		<input type="radio"/>		<input type="radio"/>
15	<input type="radio"/>		<input type="radio"/>		<input type="radio"/>		<input type="radio"/>		<input type="radio"/>		<input type="radio"/>	35	<input type="radio"/>		<input type="radio"/>		<input type="radio"/>		<input type="radio"/>		<input type="radio"/>
16	<input type="radio"/>		<input type="radio"/>		<input type="radio"/>		<input type="radio"/>		<input type="radio"/>		<input type="radio"/>	36	<input type="radio"/>		<input type="radio"/>		<input type="radio"/>		<input type="radio"/>		<input type="radio"/>
17	<input type="radio"/>		<input type="radio"/>		<input type="radio"/>		<input type="radio"/>		<input type="radio"/>		<input type="radio"/>	37	<input type="radio"/>		<input type="radio"/>		<input type="radio"/>		<input type="radio"/>		<input type="radio"/>
18	<input type="radio"/>		<input type="radio"/>		<input type="radio"/>		<input type="radio"/>		<input type="radio"/>		<input type="radio"/>	38	<input type="radio"/>		<input type="radio"/>		<input type="radio"/>		<input type="radio"/>		<input type="radio"/>
19	<input type="radio"/>		<input type="radio"/>		<input type="radio"/>		<input type="radio"/>		<input type="radio"/>		<input type="radio"/>	39	<input type="radio"/>		<input type="radio"/>		<input type="radio"/>		<input type="radio"/>		<input type="radio"/>
20	<input type="radio"/>		<input type="radio"/>		<input type="radio"/>		<input type="radio"/>		<input type="radio"/>		<input type="radio"/>	40	<input type="radio"/>		<input type="radio"/>		<input type="radio"/>		<input type="radio"/>		<input type="radio"/>
	<input type="radio"/>		<input type="radio"/>		<input type="radio"/>		<input type="radio"/>		<input type="radio"/>		<input type="radio"/>	70	<input type="radio"/>		<input type="radio"/>		<input type="radio"/>		<input type="radio"/>		<input type="radio"/>
	<input type="radio"/>		<input type="radio"/>		<input type="radio"/>		<input type="radio"/>		<input type="radio"/>		<input type="radio"/>	100	<input type="radio"/>		<input type="radio"/>		<input type="radio"/>		<input type="radio"/>		<input type="radio"/>

• Do not fold or bend sheet
• Erase mistakes completely

• Use pencil or dark pen
• Fill circle fully



'A'=YES it meets this criteria
'B' = NO it does NOT meet this criteria
SMAW FINAL

1	Has surface slag, spatter, and smoke been removed from all of the joints and surrounding areas?
2	Is the Project Assembled In Accordance to the Drawing?
3	Does the overall workmanship display consistency among all welds? (ALL WELDS MUST BE GENERALLY CONSISTENT WITH NO SIGNIFICANT DISCONTUNITUIES)
4	Weld # _____ Crack Propagation. Any crack is unacceptable. Are there no visible cracks? (Yes= "Yes, there are no visible cracks)
5	Weld # _____ Crater Cross Section. All craters should be filled to provide the specified weld size, except for the end of intermittent fillet welds outside of their effective length. Are the weld craters completely filled to the weld size?
6	Weld # _____ Overall bead width not to exceed 1/16 in. variation in width (from max to min) for any weld face. Does the weld meet this requirement?
7	Weld # _____ Porosity. No visible porosity is acceptable, Does the Weld Meet this Requirement?
8	Weld # _____ Undercut. Not to exceed 1/32 in depth for a total accumulated length of 1/2in. Does the weld meet this requirement?
9	Weld # _____ Undersized Welds. Weld Size not to be larger by anything greater than 1/16 in. anywhere along the weld length and no smaller than specified on the drawing. Does the weld size meet this requirement?
10	Weld # _____ Weld Profiles. Fillet welds can be slightly concave, flat, or slightly convex with the crown not to exceed 3/32 in. above flush. Groove Welds can be flush with an even crown not to exceed 3/32 in. Does this weld meet this requirement?
11	Weld # _____ Weld/Base metal Fusion. Complete fusion shall exist between base and weld metal. Does the weld display complete fusion with no cold lap?
12	Weld # _____ There shall be no Arc Marks outside the weld area. Does the weld meet this requirement?

Assembly
Questions

NOTE: This Final criteria is designed to follow AWD D1.1 table 6.1 Visual inspection criteria as a start, but much more difficult. Picking three top performing welds requires that the evaluation is more strict than code. We hope to eventually add tiers of quality to these questions that fall in line with the World Skills Welding Scoring Criteria which is extremely strict to be able to separate near perfect welds to determine a rank. In the future as competition welding performance improves over time these questions will evolve.



Was there a safety infraction? BE SURE TO NOTE The Competitor Number and Explain the safety violation on the Safety Infraction Sheet.

'A'=YES meets criteria
'B'=NO. Does Not meet Criteria

SMAW IPJ

1	Spot Check #1 Is the amperage within range specified on the WPS for the Electrode Currently being used?
2	Spot Check #1 Is the correct electrode being used on the weld being evaluated at the moment?
3	Spot Check #2 Is the amperage within range specified on the WPS?
4	Spot Check #2 Is the correct electrode being used on the weld being evaluated at the moment?

NOTE: This IPJ (in-process judging) is designed to be a random check as 1 inspector walks down the line 2 times, and at the moment they are walking by each station, they check this criteria. This models on the job random QA inspection to ensure welding procedures are followed. FOR SMAW, when different electrode types are being employed, it is difficult to ensure that the inspection happens when the competitor is welding with a specific electrode unless you have a much smaller group to evaluate. This method looks at the electrode being used at the moment of inspection and again is mainly evaluating whether or not the competitor is following welding procedures or not.



Was there a safety infraction? BE SURE TO NOTE The Competitor Number and Explain the safety violation on the Safety Infraction Sheet.

'A'=YES it meets this criteria
'B' = NO it does NOT meet this criteria

PAC FINAL

1	Does the bevel angle stay within +/- 5 degrees in any location a its entire length? (Use angle finder tool)
2	Which sample does the cut quality of the STRAIGHT CUT most consistently match? (AWS C4.1 GAUGE Surface Roughness Guide for Oxygen Cutting A-Sample One, B-Sample Two, C-Sample Three, D-Sample Four)
3	Which sample does the cut quality of the SQUARE HOLE most consistently match? (AWS C4.1 GAUGE Surface Roughness Guide for Oxygen Cutting A-Sample One, B-Sample Two, C-Sample Three, D-Sample Four)
4	Which sample does the cut quality of the CIRCLE most consistently match? (AWS C4.1 GAUGE Surface Roughness Guide for Oxygen Cutting A-Sample One, B-Sample Two, C-Sample Three, D-Sample Four)
5	Which sample does the cut quality of the HOCKEY STICK most consistently match? (AWS C4.1 GAUGE Surface Roughness Guide for Oxygen Cutting A-Sample One, B-Sample Two, C-Sample Three, D-Sample Four)
6	Does the cut stay inside the diameter of the Go / no-go gauge for the SQUARE?
7	Does the cut stay inside the diameter of the Go / no-go gauge for the CIRCLE?
8	Does the cut stay inside the diameter of the Go / no-go gauge for The HOCKEY STICK?
9	Does the Go / no-go gauge fit inside of the SQUARE HOLE?
10	Does the Go / no-go gauge fit inside of the CIRCLE?
11	Does the Go / no-go gauge fit inside of the HOCKEY STICK?



AWS C4.1 GAUGE Surface Roughness Guide for Oxygen Cutting
A = Sample One LOWEST QUALITY,

B = Sample Two Better than 'A'

C = Sample Three Better than 'B'

D = Sample Four HIGHEST QUALITY



Was their a safety infraction? BE SURE TO NOTE The Competitor Number and Explain the safety violation on the Safety Infraction Sheet.

NOTE: This scoring criteria uses go-no go gauges to measure the cut. The Gauge is cut 0.1 in. to either side of the line. You may find you need to eliminate or add questions.

Item	Qty.	Description
A	1	0.25 x 6 x 6.5

ALL PROCESSES TO BE COMPLETED WITH THE MATERIALS PROVIDED

NOTE: PERFORM A SQUARE CUT ALONG DASHED LINE

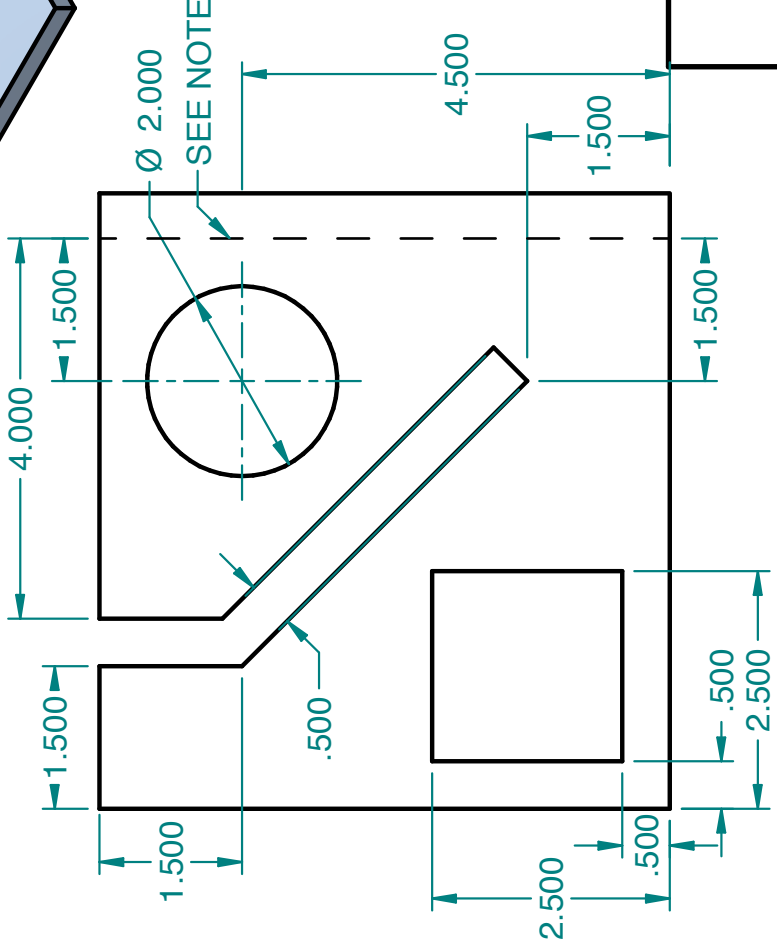
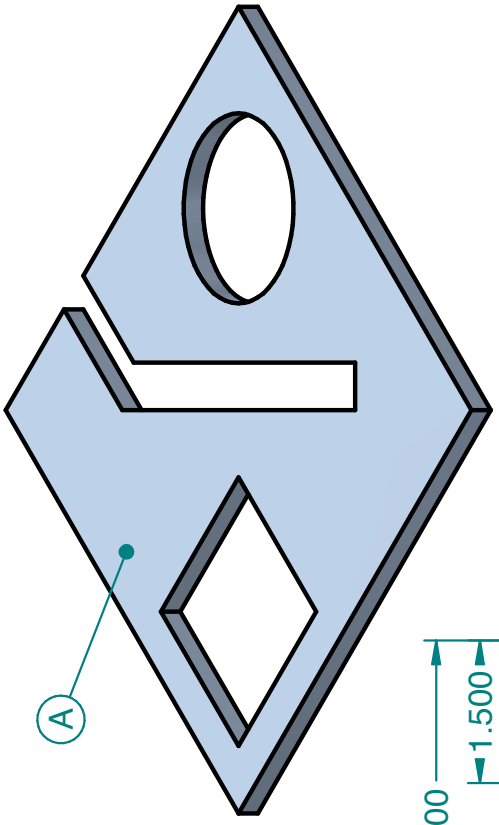

UNLESS OTHERWISE SPECIFIED DIMENSIONS ARE IN INCHES

SkillsUSA Welding Contest	
TITLE	PAC or OFC
SIZE	A
SHEET 1 OF 1	

'A'=YES it meets this criteria
'B' = NO it does NOT meet this criteria
OFC FINAL

1	Does the bevel angle stay within +/- 5 degrees in any location along its entire length? (Use angle finder tool)
2	Which sample does the cut quality of the STRAIGHT CUT most consistently match? (AWS C4.1 GAUGE Surface Roughness Guide for Oxygen Cutting A-Sample One, B-Sample Two, C-Sample Three, D-Sample Four)
3	Which sample does the cut quality of the SQUARE HOLE most consistently match? (AWS C4.1 GAUGE Surface Roughness Guide for Oxygen Cutting A-Sample One, B-Sample Two, C-Sample Three, D-Sample Four)
4	Which sample does the cut quality of the CIRCLE most consistently match? (AWS C4.1 GAUGE Surface Roughness Guide for Oxygen Cutting A-Sample One, B-Sample Two, C-Sample Three, D-Sample Four)
5	Which sample does the cut quality of the HOCKEY STICK most consistently match? (AWS C4.1 GAUGE Surface Roughness Guide for Oxygen Cutting A-Sample One, B-Sample Two, C-Sample Three, D-Sample Four)
6	Does the cut stay inside the diameter of the Go / no-go gauge for the SQUARE?
7	Does the cut stay inside the diameter of the Go / no-go gauge for the CIRCLE?
8	Does the cut stay inside the diameter of the Go / no-go gauge for The HOCKEY STICK?
9	Does the Go / no-go gauge fit inside of the SQUARE HOLE?
10	Does the Go / no-go gauge fit inside of the CIRCLE?
11	Does the Go / no-go gauge fit inside of the HOCKEY STICK?
12	Is the BEVEL CUT accuracy along its length Straight to within no more than a variation of 1/8 in.? (Align Go / no-go template at sides and measure to determine tolerance)



AWS C4.1 GAUGE
Surface Roughness
Guide for Oxygen
Cutting
**A = Sample One
LOWEST QUALITY,**

**B = Sample Two
Better than 'A'**

**C = Sample Three
Better than 'B'**

**D = Sample Four
HIGHEST QUALITY**



Was there a safety infraction? BE SURE TO NOTE The Competitor Number and Explain the safety violation on the Safety Infraction Sheet.

NOTE: This scoring criteria uses go-no go gauges to measure the cut. The Gauge is cut 0.1 in. to either side of the line. You may find you need to eliminate or add questions.

Name	Class	Quiz
		OFC/PAC

Student ZipGrade ID

0	<input type="radio"/>	<input type="radio"/>	<input type="radio"/>	<input type="radio"/>	<input type="radio"/>	<input type="radio"/>	<input type="radio"/>	<input type="radio"/>	<input type="radio"/>	<input type="radio"/>	<input type="radio"/>
1	<input type="radio"/>	<input type="radio"/>	<input type="radio"/>	<input type="radio"/>	<input type="radio"/>	<input type="radio"/>	<input type="radio"/>	<input type="radio"/>	<input type="radio"/>	<input type="radio"/>	<input type="radio"/>
2	<input type="radio"/>	<input type="radio"/>	<input type="radio"/>	<input type="radio"/>	<input type="radio"/>	<input type="radio"/>	<input type="radio"/>	<input type="radio"/>	<input type="radio"/>	<input type="radio"/>	<input type="radio"/>
3	<input type="radio"/>	<input type="radio"/>	<input type="radio"/>	<input type="radio"/>	<input type="radio"/>	<input type="radio"/>	<input type="radio"/>	<input type="radio"/>	<input type="radio"/>	<input type="radio"/>	<input type="radio"/>
4	<input type="radio"/>	<input type="radio"/>	<input type="radio"/>	<input type="radio"/>	<input type="radio"/>	<input type="radio"/>	<input type="radio"/>	<input type="radio"/>	<input type="radio"/>	<input type="radio"/>	<input type="radio"/>
5	<input type="radio"/>	<input type="radio"/>	<input type="radio"/>	<input type="radio"/>	<input type="radio"/>	<input type="radio"/>	<input type="radio"/>	<input type="radio"/>	<input type="radio"/>	<input type="radio"/>	<input type="radio"/>
6	<input type="radio"/>	<input type="radio"/>	<input type="radio"/>	<input type="radio"/>	<input type="radio"/>	<input type="radio"/>	<input type="radio"/>	<input type="radio"/>	<input type="radio"/>	<input type="radio"/>	<input type="radio"/>
7	<input type="radio"/>	<input type="radio"/>	<input type="radio"/>	<input type="radio"/>	<input type="radio"/>	<input type="radio"/>	<input type="radio"/>	<input type="radio"/>	<input type="radio"/>	<input type="radio"/>	<input type="radio"/>
8	<input type="radio"/>	<input type="radio"/>	<input type="radio"/>	<input type="radio"/>	<input type="radio"/>	<input type="radio"/>	<input type="radio"/>	<input type="radio"/>	<input type="radio"/>	<input type="radio"/>	<input type="radio"/>
9	<input type="radio"/>	<input type="radio"/>	<input type="radio"/>	<input type="radio"/>	<input type="radio"/>	<input type="radio"/>	<input type="radio"/>	<input type="radio"/>	<input type="radio"/>	<input type="radio"/>	<input type="radio"/>

Key

A	<input type="radio"/>
B	<input type="radio"/>
C	<input type="radio"/>
D	<input type="radio"/>
E	<input type="radio"/>

	■	A	B	C	D	E		■	A	B	C	D	E
41	<input type="radio"/>	<input type="radio"/>	<input type="radio"/>	<input type="radio"/>	<input type="radio"/>	<input type="radio"/>		71	<input type="radio"/>	<input type="radio"/>	<input type="radio"/>	<input type="radio"/>	<input type="radio"/>
42	<input type="radio"/>	<input type="radio"/>	<input type="radio"/>	<input type="radio"/>	<input type="radio"/>	<input type="radio"/>		72	<input type="radio"/>	<input type="radio"/>	<input type="radio"/>	<input type="radio"/>	<input type="radio"/>
43	<input type="radio"/>	<input type="radio"/>	<input type="radio"/>	<input type="radio"/>	<input type="radio"/>	<input type="radio"/>		73	<input type="radio"/>	<input type="radio"/>	<input type="radio"/>	<input type="radio"/>	<input type="radio"/>
44	<input type="radio"/>	<input type="radio"/>	<input type="radio"/>	<input type="radio"/>	<input type="radio"/>	<input type="radio"/>		74	<input type="radio"/>	<input type="radio"/>	<input type="radio"/>	<input type="radio"/>	<input type="radio"/>
45	<input type="radio"/>	<input type="radio"/>	<input type="radio"/>	<input type="radio"/>	<input type="radio"/>	<input type="radio"/>		75	<input type="radio"/>	<input type="radio"/>	<input type="radio"/>	<input type="radio"/>	<input type="radio"/>
46	<input type="radio"/>	<input type="radio"/>	<input type="radio"/>	<input type="radio"/>	<input type="radio"/>	<input type="radio"/>		76	<input type="radio"/>	<input type="radio"/>	<input type="radio"/>	<input type="radio"/>	<input type="radio"/>
47	<input type="radio"/>	<input type="radio"/>	<input type="radio"/>	<input type="radio"/>	<input type="radio"/>	<input type="radio"/>		77	<input type="radio"/>	<input type="radio"/>	<input type="radio"/>	<input type="radio"/>	<input type="radio"/>
48	<input type="radio"/>	<input type="radio"/>	<input type="radio"/>	<input type="radio"/>	<input type="radio"/>	<input type="radio"/>		78	<input type="radio"/>	<input type="radio"/>	<input type="radio"/>	<input type="radio"/>	<input type="radio"/>
49	<input type="radio"/>	<input type="radio"/>	<input type="radio"/>	<input type="radio"/>	<input type="radio"/>	<input type="radio"/>		79	<input type="radio"/>	<input type="radio"/>	<input type="radio"/>	<input type="radio"/>	<input type="radio"/>
50	<input type="radio"/>	<input type="radio"/>	<input type="radio"/>	<input type="radio"/>	<input type="radio"/>	<input type="radio"/>		80	<input type="radio"/>	<input type="radio"/>	<input type="radio"/>	<input type="radio"/>	<input type="radio"/>

	A	B	C	D	E	■	A	B	C	D	E	■	A	B	C	D	E										
1	<input type="radio"/>	<input type="radio"/>	<input type="radio"/>	<input type="radio"/>	<input type="radio"/>		21	<input type="radio"/>	<input type="radio"/>	<input type="radio"/>	<input type="radio"/>		51	<input type="radio"/>	<input type="radio"/>	<input type="radio"/>	<input type="radio"/>	81	<input type="radio"/>	<input type="radio"/>	<input type="radio"/>	<input type="radio"/>					
2	<input type="radio"/>	<input type="radio"/>	<input type="radio"/>	<input type="radio"/>	<input type="radio"/>		22	<input type="radio"/>	<input type="radio"/>	<input type="radio"/>	<input type="radio"/>		52	<input type="radio"/>	<input type="radio"/>	<input type="radio"/>	<input type="radio"/>	82	<input type="radio"/>	<input type="radio"/>	<input type="radio"/>	<input type="radio"/>					
3	<input type="radio"/>	<input type="radio"/>	<input type="radio"/>	<input type="radio"/>	<input type="radio"/>		23	<input type="radio"/>	<input type="radio"/>	<input type="radio"/>	<input type="radio"/>		53	<input type="radio"/>	<input type="radio"/>	<input type="radio"/>	<input type="radio"/>	83	<input type="radio"/>	<input type="radio"/>	<input type="radio"/>	<input type="radio"/>					
4	<input type="radio"/>	<input type="radio"/>	<input type="radio"/>	<input type="radio"/>	<input type="radio"/>		24	<input type="radio"/>	<input type="radio"/>	<input type="radio"/>	<input type="radio"/>		54	<input type="radio"/>	<input type="radio"/>	<input type="radio"/>	<input type="radio"/>	84	<input type="radio"/>	<input type="radio"/>	<input type="radio"/>	<input type="radio"/>					
5	<input type="radio"/>	<input type="radio"/>	<input type="radio"/>	<input type="radio"/>	<input type="radio"/>		25	<input type="radio"/>	<input type="radio"/>	<input type="radio"/>	<input type="radio"/>		55	<input type="radio"/>	<input type="radio"/>	<input type="radio"/>	<input type="radio"/>	85	<input type="radio"/>	<input type="radio"/>	<input type="radio"/>	<input type="radio"/>					
6	<input type="radio"/>	<input type="radio"/>	<input type="radio"/>	<input type="radio"/>	<input type="radio"/>		26	<input type="radio"/>	<input type="radio"/>	<input type="radio"/>	<input type="radio"/>		56	<input type="radio"/>	<input type="radio"/>	<input type="radio"/>	<input type="radio"/>	86	<input type="radio"/>	<input type="radio"/>	<input type="radio"/>	<input type="radio"/>					
7	<input type="radio"/>	<input type="radio"/>	<input type="radio"/>	<input type="radio"/>	<input type="radio"/>		27	<input type="radio"/>	<input type="radio"/>	<input type="radio"/>	<input type="radio"/>		57	<input type="radio"/>	<input type="radio"/>	<input type="radio"/>	<input type="radio"/>	87	<input type="radio"/>	<input type="radio"/>	<input type="radio"/>	<input type="radio"/>					
8	<input type="radio"/>	<input type="radio"/>	<input type="radio"/>	<input type="radio"/>	<input type="radio"/>		28	<input type="radio"/>	<input type="radio"/>	<input type="radio"/>	<input type="radio"/>		58	<input type="radio"/>	<input type="radio"/>	<input type="radio"/>	<input type="radio"/>	88	<input type="radio"/>	<input type="radio"/>	<input type="radio"/>	<input type="radio"/>					
9	<input type="radio"/>	<input type="radio"/>	<input type="radio"/>	<input type="radio"/>	<input type="radio"/>		29	<input type="radio"/>	<input type="radio"/>	<input type="radio"/>	<input type="radio"/>		59	<input type="radio"/>	<input type="radio"/>	<input type="radio"/>	<input type="radio"/>	89	<input type="radio"/>	<input type="radio"/>	<input type="radio"/>	<input type="radio"/>					
10	<input type="radio"/>	<input type="radio"/>	<input type="radio"/>	<input type="radio"/>	<input type="radio"/>		30	<input type="radio"/>	<input type="radio"/>	<input type="radio"/>	<input type="radio"/>		60	<input type="radio"/>	<input type="radio"/>	<input type="radio"/>	<input type="radio"/>	90	<input type="radio"/>	<input type="radio"/>	<input type="radio"/>	<input type="radio"/>					
	A	B	C	D	E			■	A	B	C	D	E		■	A	B	C	D	E		■	A	B	C	D	E
11	<input type="radio"/>	<input type="radio"/>	<input type="radio"/>	<input type="radio"/>	<input type="radio"/>		31	<input type="radio"/>	<input type="radio"/>	<input type="radio"/>	<input type="radio"/>		61	<input type="radio"/>	<input type="radio"/>	<input type="radio"/>	<input type="radio"/>	91	<input type="radio"/>	<input type="radio"/>	<input type="radio"/>	<input type="radio"/>	<input type="radio"/>	<input type="radio"/>	<input type="radio"/>	<input type="radio"/>	
12	<input type="radio"/>	<input type="radio"/>	<input type="radio"/>	<input type="radio"/>	<input type="radio"/>		32	<input type="radio"/>	<input type="radio"/>	<input type="radio"/>	<input type="radio"/>		62	<input type="radio"/>	<input type="radio"/>	<input type="radio"/>	<input type="radio"/>	92	<input type="radio"/>	<input type="radio"/>	<input type="radio"/>	<input type="radio"/>	<input type="radio"/>	<input type="radio"/>	<input type="radio"/>	<input type="radio"/>	
13	<input type="radio"/>	<input type="radio"/>	<input type="radio"/>	<input type="radio"/>	<input type="radio"/>		33	<input type="radio"/>	<input type="radio"/>	<input type="radio"/>	<input type="radio"/>		63	<input type="radio"/>	<input type="radio"/>	<input type="radio"/>	<input type="radio"/>	93	<input type="radio"/>	<input type="radio"/>	<input type="radio"/>	<input type="radio"/>	<input type="radio"/>	<input type="radio"/>	<input type="radio"/>	<input type="radio"/>	
14	<input type="radio"/>	<input type="radio"/>	<input type="radio"/>	<input type="radio"/>	<input type="radio"/>		34	<input type="radio"/>	<input type="radio"/>	<input type="radio"/>	<input type="radio"/>		64	<input type="radio"/>	<input type="radio"/>	<input type="radio"/>	<input type="radio"/>	94	<input type="radio"/>	<input type="radio"/>	<input type="radio"/>	<input type="radio"/>	<input type="radio"/>	<input type="radio"/>	<input type="radio"/>	<input type="radio"/>	
15	<input type="radio"/>	<input type="radio"/>	<input type="radio"/>	<input type="radio"/>	<input type="radio"/>		35	<input type="radio"/>	<input type="radio"/>	<input type="radio"/>	<input type="radio"/>		65	<input type="radio"/>	<input type="radio"/>	<input type="radio"/>	<input type="radio"/>	95	<input type="radio"/>	<input type="radio"/>	<input type="radio"/>	<input type="radio"/>	<input type="radio"/>	<input type="radio"/>	<input type="radio"/>	<input type="radio"/>	
16	<input type="radio"/>	<input type="radio"/>	<input type="radio"/>	<input type="radio"/>	<input type="radio"/>		36	<input type="radio"/>	<input type="radio"/>	<input type="radio"/>	<input type="radio"/>		66	<input type="radio"/>	<input type="radio"/>	<input type="radio"/>	<input type="radio"/>	96	<input type="radio"/>	<input type="radio"/>	<input type="radio"/>	<input type="radio"/>	<input type="radio"/>	<input type="radio"/>	<input type="radio"/>	<input type="radio"/>	
17	<input type="radio"/>	<input type="radio"/>	<input type="radio"/>	<input type="radio"/>	<input type="radio"/>		37	<input type="radio"/>	<input type="radio"/>	<input type="radio"/>	<input type="radio"/>		67	<input type="radio"/>	<input type="radio"/>	<input type="radio"/>	<input type="radio"/>	97	<input type="radio"/>	<input type="radio"/>	<input type="radio"/>	<input type="radio"/>	<input type="radio"/>	<input type="radio"/>	<input type="radio"/>	<input type="radio"/>	
18	<input type="radio"/>	<input type="radio"/>	<input type="radio"/>	<input type="radio"/>	<input type="radio"/>		38	<input type="radio"/>	<input type="radio"/>	<input type="radio"/>	<input type="radio"/>		68	<input type="radio"/>	<input type="radio"/>	<input type="radio"/>	<input type="radio"/>	98	<input type="radio"/>	<input type="radio"/>	<input type="radio"/>	<input type="radio"/>	<input type="radio"/>	<input type="radio"/>	<input type="radio"/>	<input type="radio"/>	
19	<input type="radio"/>	<input type="radio"/>	<input type="radio"/>	<input type="radio"/>	<input type="radio"/>		39	<input type="radio"/>	<input type="radio"/>	<input type="radio"/>	<input type="radio"/>		69	<input type="radio"/>	<input type="radio"/>	<input type="radio"/>	<input type="radio"/>	99	<input type="radio"/>	<input type="radio"/>	<input type="radio"/>	<input type="radio"/>	<input type="radio"/>	<input type="radio"/>	<input type="radio"/>	<input type="radio"/>	
20	<input type="radio"/>	<input type="radio"/>	<input type="radio"/>	<input type="radio"/>	<input type="radio"/>		40	<input type="radio"/>	<input type="radio"/>	<input type="radio"/>	<input type="radio"/>		70	<input type="radio"/>	<input type="radio"/>	<input type="radio"/>	<input type="radio"/>	100	<input type="radio"/>	<input type="radio"/>	<input type="radio"/>	<input type="radio"/>	<input type="radio"/>	<input type="radio"/>	<input type="radio"/>	<input type="radio"/>	

• Do not fold or bend sheet
• Erase mistakes completely

• Use pencil or dark pen
• Fill circle fully



Appendix A - Zipgrade Tips

Zipgrade.com is a phone app that is easy to use and inexpensive. It has significantly reduced the time to record all scores then total them to determine the top finishers.

Below is an outline of tips to using zipgrade.com for creating score sheets to quickly and accurately capture score points. Creating “quizzes” in zipgrade for each of the score criteria sheets for each part of the competition is the “how” to be able to use a simple grade system to act as a scoring system.

1. Decide on Contest Areas

50	FCAW
50	GMAW
50	SMAW
25	OFC
50	GTAW
100	Knowledge Tests
325	TOTAL

2. Determine how to collect the data

- If ZipGrade will work, follow the ZipGrade instructions
ZipGrade Instructions
 - Create Quiz for each contest area and a Key
 - Import the list of Students (Contestants), linked to a Class
 - Link the Class to each quiz
 - Create Bubble Answer Sheets for each Quiz
 - Print all score sheet packets
 - Scan Bubble Sheets for Perfect Score Contestants for testing
 - Review Results in ZipGrade

- If ZipGrade will not work, use Excel to capture the totals per contest area
 - Setup separate tabs to capture scores per contest area
 - Easiest to capture scores as they come in, and not fill in all contestant numbers to start. Once all scores are entered, data can be sorted by Contestant #.
 - Determine how to capture scores in the contest area and print out score sheets
 - Input Perfect Score Contestants into XLS tab(s) for testing.

Note: All data is managed by Contestant# (no names required, each contestant gets a unique number in zipgrade for tracking all scores)

3. Combine the ZipGrade totals with XLS totals.

- Copy & Paste Grade book into XLS final score sheet
- Copy & Paste XLS scores into XLS final score sheet

4. Convert the totals into the SkillsUSA required points (use the Multiplier to convert)

Note: The example below shows how you determine the multiplier and the Factored Score is equal to the perfect score. You make up your contest and your actual points any way you want, and in the end, you convert your points into the points you need to turn into SkillsUSA.

In the example below, SkillsUSA wants your total points to be 500. So, you take each actual score and multiply it by the Multiplier. To determine the multiplier you divide the Actual Total by the SkillsUSA Total and you have a multiplier to reach an established final score regardless of how you assign score points. It saves significant time determining how many points every item you are evaluating should be in order to reach the determined number

It's easier to collect the totals in the Grade book format, so the contestant # is on the left and the contest area is at the top. When you setup the conversion routine, format the sheet columns in the order you give to SkillsUSA.

- Once all scores have been collected paste the final values into the SkillsUSA Scorecard.
- Subtract any safety violations/penalties Manually enter any safety violations/penalties per contestant directly into the SkillsUSA Scorecard

	Actual Total Points	SkillsUSA Total Points	Multiplier (=Actual Total / SkillsUSA Total)
	965	500	0.518134715
Contest Area	Input	Factored Score *	
Contest-Section-1	350	181.3471503	
Contest-Section-2	300	155.4404145	
Contest-Section-3	200	103.626943	
Contest-Section-4	100	51.8134715	
Contest-Section-5	15	7.772020725	
	965	500	SUM
			* Factored Score = Actual Score x Multiplier

ZIPGRADE OVERVIEW

You will need to login to WWW.ZIPGRADE.COM and register. Once registered, you can use the same logon via the mobile application or the website application. All individuals on your scoring team can use the same logon to capture the scores in the same cloud account. It's important to understand that certain functions are performed on your phone, while others are only available via the website application.

Mobile Application	Website Application
<p>Create Quiz</p> <ul style="list-style-type: none"> Load Key via scan or type in answers Set points per question (limited to two decimal places) Link class to Quiz <p>Enter Scores</p> <ul style="list-style-type: none"> Select Quiz, Scan Papers Review Scores/Paper Edit Answers (if bad scan) <p>Sync to Cloud (manually or automatic)</p>	<p>Manage Students</p> <ul style="list-style-type: none"> Upload via CSV file Edit - Add/Change/Delete Link student to Class (via upload or manually) <p>Bubble Sheets</p> <ul style="list-style-type: none"> Print Bubble Sheets per class/pre-numbered Print Blank Bubble Sheets <p>Grade Report</p> <ul style="list-style-type: none"> Use grade report to obtain all scores for all papers graded
<p>Quiz Results</p> <ul style="list-style-type: none"> Item Analysis (see total correct per question) - not easily seen on mobile app 	<p>Quiz Results</p> <ul style="list-style-type: none"> Quiz Details & Stats - includes Item Analysis, Score Distribution graph, Graded Papers with scores. Much better visibility of overall contest results than on mobile app. <p>Archive</p> <p>In 2018, we agreed to keep all students (High School as 100 thru 170 and College as 500 thru 525) and copy all required Quizzes from year to year. Once copied, archive the prior year's Quiz so it can't be selected during the contest.</p> <ul style="list-style-type: none"> Class - includes Class, Students and graded papers Quiz - includes Quiz and all graded papers

ZIPGRADE INITIAL SETUP (on phone)

1. Find Application in App Store

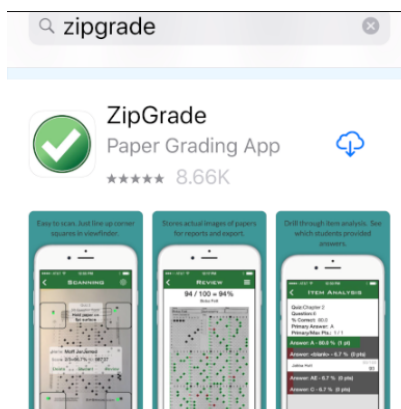

2. Download and Open application



3. Login using registered User Name and Password.



4. Press OK when the message box appears



5. Update settings to allow camera usage and cell data (it's better if you have internet service on day of contest)

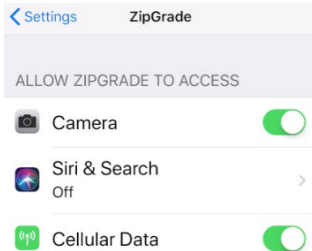

6. Check/Set the following other settings – you decide what you want here. Note: if you have trouble with your scans, adjust the sharpness & strictness bars. Important to turn on WARN BEFORE OVERWRITING and One Quiz Per Student.

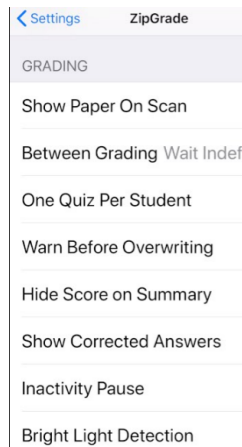
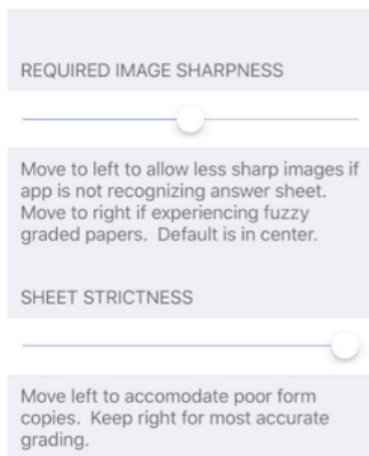

5. Update settings to allow camera usage and cell data (it's better if you have internet service on day of contest)

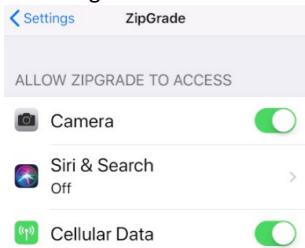

6. Check/Set the following other settings – you decide what you want here. Note: if you have trouble with your scans, adjust the sharpness & strictness bars. Important to turn on WARN BEFORE OVERWRITING and One Quiz Per Student.

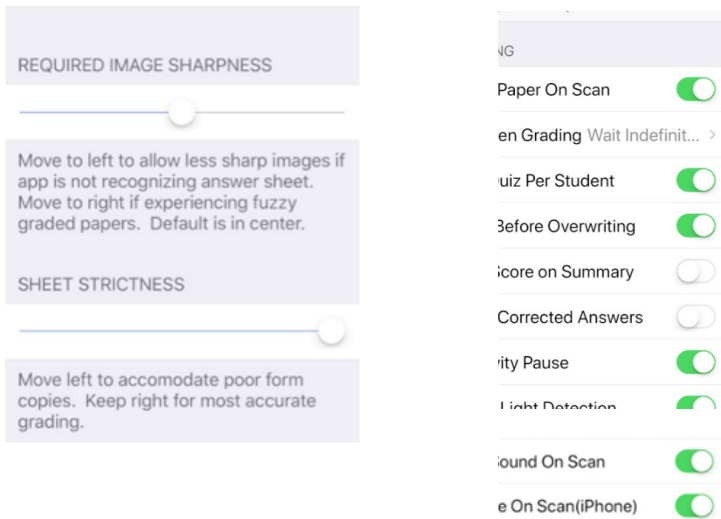

ZIPGRADE LESSONS LEARNED

- LL1 - Use Google Chrome, not IE, as copy/paste text from the Grade Book Report to Excel doesn't work in IE.
- LL2 - In Edit Key, set points per question had a max of 20.9 in the past, but is no longer limited. Can use up to four characters, but limited to two decimal places. So, can use up to 9999 or 999.9 or 99.99 per question.
- LL3 - In Edit Key, if multiple correct answers, pick both. If either answer 1 or answer 2 is correct, use Alternate Option.
- LL4 - Student ID can't exceed 9 digits (999999999).
- LL5 - Quizzes will be displayed in the Grade Book Report based on the Quiz Date. Update the date to show in the order you want.
- LL6 - Pick 100 Question form so you can print the bubble sheets with contestant number already filled in.
- LL7 - See ZipGrade Setup page for warning message if scanned multiple times for same student/quiz. If scanner doesn't overwrite, the entry will be listed twice, but will only appear in the Grade Book Report once. This has been tested and the highest score is what appears in the Grade Book Report. When the second scan was done for Student ID#2, scanner would have received a warning message. If the correct exam is selected, the appropriate answer is to Overwrite Previous.

Multiple scores for Student ID#2, appears if Keep Both is selected.

ID	Name	Score	% Correct	Key
1	1, PERFECT SCORE	20	100.0 %	A
2	2, PERFECT SCORE	20	100.0 %	A
2	2, PERFECT SCORE	2	10.0 %	A

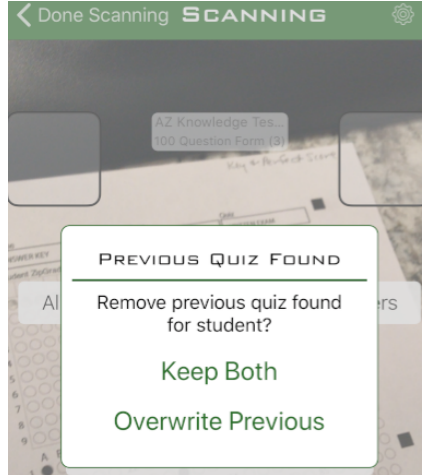

LL8 - if reviewing scores, back button appears to work to go back and select another score to view. However, it sometimes seems to lose its place, sometimes the best choice is to just select ZipGrade Section from the menu.



LL9 - Look for multiple (as shown above) and/or any papers that didn't scan properly (not linked to a StudentID). Examples, Student ID not clear, fuzzy scan, etc. Please note, graded papers can only be deleted in the mobile app.

Fuzzy Scan

Invalid graded papers don't link to a Student ID (as shown in the Quiz screens)

ID	Name	Score	% Correct	Key
1	1, PERFECT SCORE	20	100.0 %	A
2	2, PERFECT SCORE	20	100.0 %	A
		2	10.0 %	A
		2	10.0 %	A



StudentID not valid

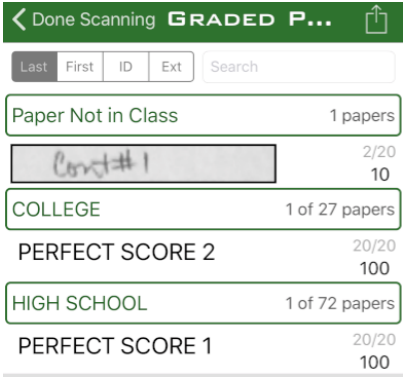
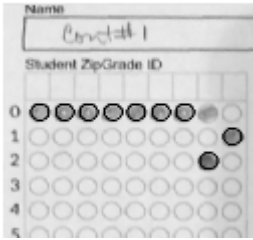

To Delete a scanned paper, slide scanned paper score to left, and select Delete

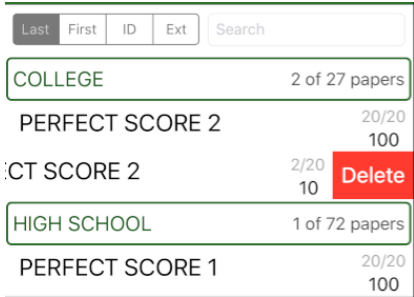

LL10 – During the contest, if you have a scoring table, it's difficult to scan all bubble sheets manually, arms/shoulders start hurting after hours of scanning. After our trial use of Zipgrade, we created some cell phone holders, to help with scanning. We could place the bubble sheets directly below the cell phone holder, stack the pages, then remove one page at a time, quickly. Scoring became much faster.

LL11 – Many bubble sheets, from many contest areas are hard to keep track of. And, if multiple scanners, it's best to have individuals scan certain contest areas, so scores from one contest area don't accidentally get saved in the wrong QUIZ. To eliminate these problems, we created scorebooks.

LL12 - In 2018, we let the judges scan their own scores. This was great, but came with new problems. If a score gets overwritten from another contest, to better identify the problem ensure all bubble sheets have the contest area listed in the QUIZ box. We created booklets and just used blank bubble sheets because the scoring booklet had a name. **Note:** We will not do that again!

It doesn't matter if you have scorebooks or loose score sheets, for best results **always pre-print the student number and the contest area!**

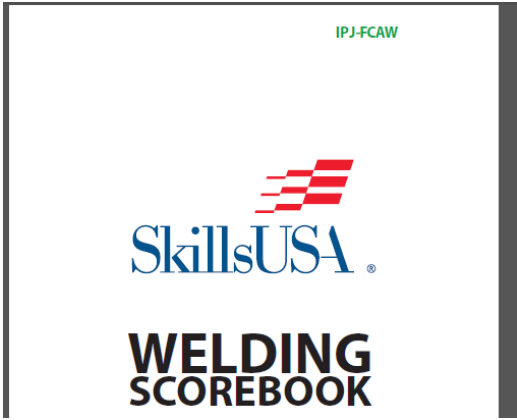

This block contains two examples of bubble sheets. The top example is labeled 'Bad Example' with a red box around the 'Quiz' field, which is empty. The 'Name' field contains 'Cont# 100' and the 'Class' field contains 'HIGH SCHOOL'. The bottom example is labeled 'Good Example' with a green box around the 'QUIZ' field, which contains 'FI-GTAW'. The 'Name' field contains 'CONT# 101' and the 'Class' field contains 'SECONDARY'. Both sheets include a 'Student ZipGrade ID' field with a key and a grid of bubbles for answers A, B, C, D, and E.

This page is intentionally blank.



American Welding Society



SkillsUSA®